

## AMS MU800 Mullion Drained Curtain Walling

The AMS MU800 mullion drained curtain walling system offers unique architectural design features combined with market leading weather performance. The system is propriety based and is suitable for both low & high rise applications. The system is visually complete with a 55mm face width.

### Introduction

The suite of profiles consist of 35mm X 55mm, 63mm X 55mm, 99mm X 55mm, 126mm X 55mm, 146mm X 55mm, with a thermal isolator, EPDM gaskets, foil backed weather tape and pressure plate allowing a thermally broken façade. There are a variety of external finishing options available in aluminium face caps.

### Thermal Performance

AMS MU800 curtain walling is designed to offer the specifier excellent aluminium thermal u-frame values in conjunction with the correct glass specification to achieve overall target u-values or equivalent energy ratings on specified projects.

### Scope

This specification defines materials, fabrication, paint finishes, and size limitations for curtain walling.

### Materials

Aluminium profiles are extruded from aluminium alloy 6063 T5 and T6 complying with BS1474 – BS EN 12020-2:2001 / BS EN 755-9:2001.

### Paint Finishes

#### Polyester Powder Coatings

Aluminium profiles can be dual colour polyester powder coated to BS6496.

AMS offers in house painting with the following paint suppliers :

- Azko Nobel Interpon D
- Du Pont Alesta
- Beckers Powder

#### Decoral

Aluminium profiles can be polyester powder coated with a woodgrain effect paint finish to BS6496.

#### Anodised

Aluminium profiles can be anodised to BS1615 or BS3987.

## Fabrication

The AMS MU800 curtain walling system is designed as a stick system and frame members such as mullions and transoms shall be fabricated in accordance with AMS technical literature and transported to site as prepared components. The stick grid system shall be assembled on the proposed facade area as per fabrication shop drawings and architects instructions.

Mullions shall be square cut and profiles shall be joined specially with jointing spigots. Mullions shall run the full height of the façade with transoms spanning in between and these shall be notched and screw fixed to the mullion. Transoms shall have notched ends to ensure a weather proof joint.

Fixing points should be advised by a structural engineer and relevant fixing brackets approved so that all loads are transferred back to the main building structure. Low modulus silicone shall be used throughout for weathering joints as recommended by the silicone manufacturer.

## Glazing

Glass shall be set against extruded gaskets internally which are fitted into gasket grooves in the mullions and transoms. Gaskets shall be to BS 4255: EPDM. The system can accommodate 22mm, 24mm, 28 mm and 32mm double glazed insulating units. Glazing shall be to BS 6262 and Building Regulations Document N.

## Installation

AMS offer detailed installation instructions on all systems and these should be followed as per AMS's technical department's recommendations.

## Structure

Section performance requirements must be calculated from site conditions and all loading requirements. All structural profiles shall be designed so as the maximum deflection of any member shall not exceed  $L/175$  of its span and there shall be no evidence of any permanent deformation once the load has been removed.

## Performance

Tested to BS 6375-Part 1.  
Air Permeability - 600 Pa.  
Water Tightness - 600 Pa.  
Wind Resistance - 2400 Pa.

Tested to CWCT standards.  
Sequence B Test.

## Insert Opening Vents & Doors

Details and specification information for these insert products can be found in the window and door section of AMS's technical literature.

- 1.1.01 B: Profile listing, Mullion/Transoms.
- 1.1.02 B: Profile listing, cappings.
- 1.1.03 D: Gaskets and accessories.
- 1.1.04 C: Accessories.
- 1.1.05 : Brackets.
- 1.1.06 : lxx of Mullions sleeved.
- 1.1.07 : Profile assembly.
- 1.1.08 B: Gapping options.
- 1.1.09 B: Glazing options - Mullions.
- 1.1.10 C: Glazing options - Transoms
- 1.1.11 : System applications.
- 1.1.12 B: Typical head details.
- 1.1.13 B: Typical head detail into kingspan panels.
- 1.1.14 C: Typical cill details
- 1.1.15 B: Typical mid span fixing.
- 1.1.16 B: Typical mid span fixing.
- 1.1.17 A: Typical sash insert - 24mm.
- 1.1.18 B: Concealed sash detail.
- 1.1.19 B: Typical sash insert - 28mm.
- 1.1.20 B: Typical door head detail.
- 1.1.21 B: Typical jamb detail.
- 1.1.22 B: Typical door jamb detail.
- 1.1.23 B: Corner details.
- 1.1.24 B: Sloped glazing - head detail.
- 1.1.25 B: Sloped glazing - eaves detail.
- 1.1.26 B: Sloped glazing - jamb detail.
- 1.1.27 B: False mullion detail.
- 1.1.28 B: Typical ridge detail.
- 1.1.29 B: Typical ridge detail.
- 1.1.30 B: Double transom ridge detail
- 1.1.31 C: Sloped glazing - cill detail
- 1.1.32 A: Typical details MU899-60 (60mm transom)
- 1.1.33 A: Insert details

**AMS Ltd. Wallingstown, Little Island, Co. Cork:**

**Tel:** 021 4705100 **Fax:** 021 4705198, **E-mail:** pohara@ams.ie, **Web:** www.ams.ie



# MU 800 SERIES MULLION DRAINED SYSTEM

## Mullions and transoms

Scale NTS

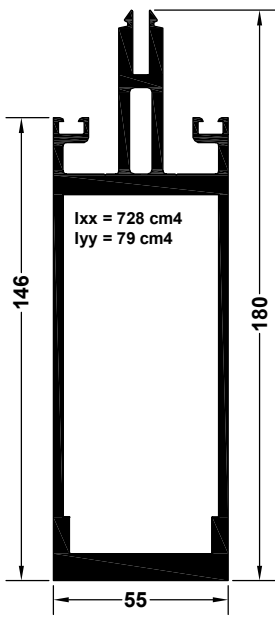

**MU 898  
MULLION**

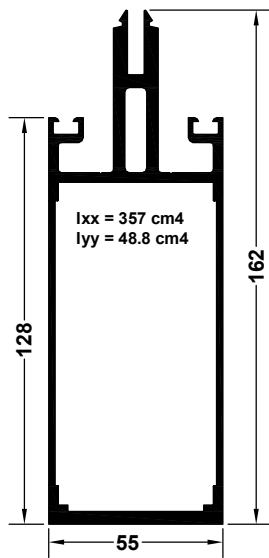

**MU 882  
MULLION**

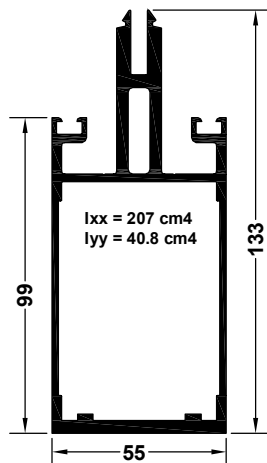

**MU 895  
MULLION**

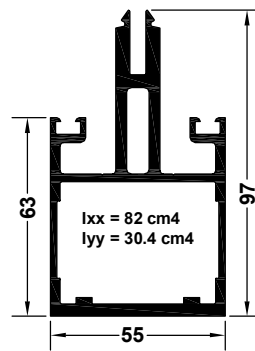

**MU 892  
MULLION**

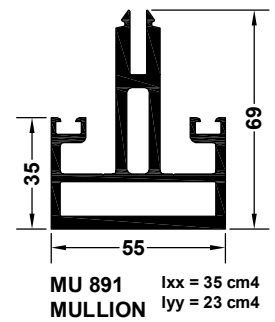

**MU 891  
MULLION** Ixx = 35 cm4  
Iyy = 23 cm4

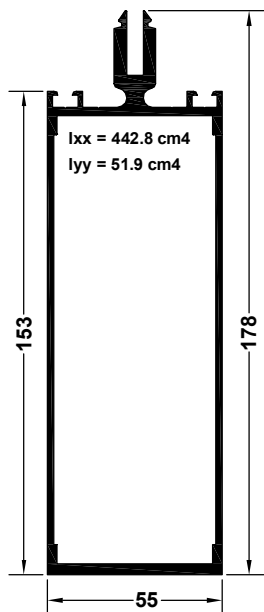

**MU 899  
TRANSOM**

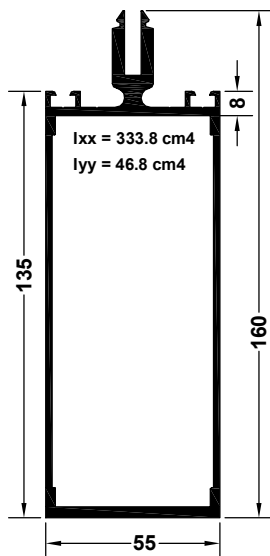

**MU 894  
TRANSOM**

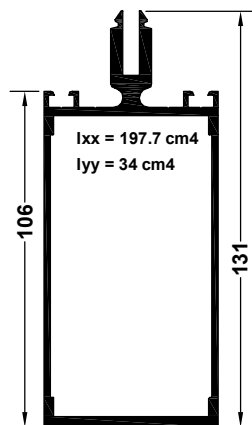

**MU 896  
TRANSOM**

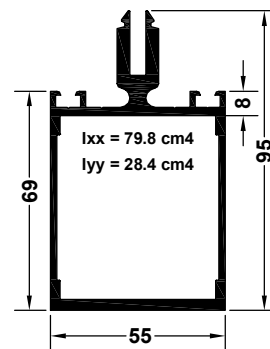

**MU 883  
TRANSOM**

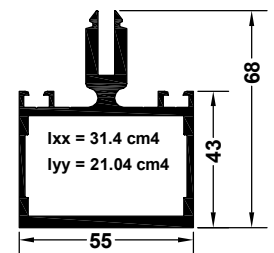

**MU 826  
ROOF TRANSOM**

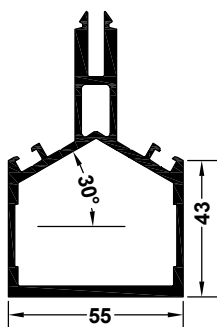

**MU 827  
30° RIDGE BAR**

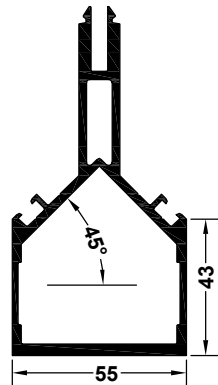

**MU 828  
45° RIDGE BAR**

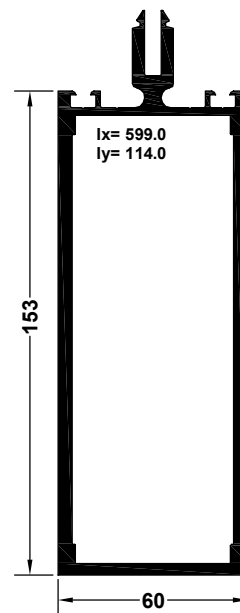

**MU 899-60  
TRANSOM**

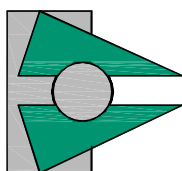

# MU 800 SERIES MULLION DRAINED SYSTEM

Cappings and pressure plates

Scale 1:2

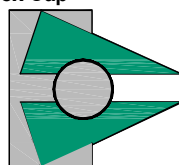
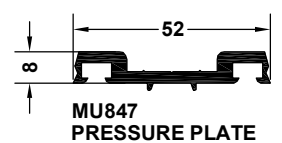
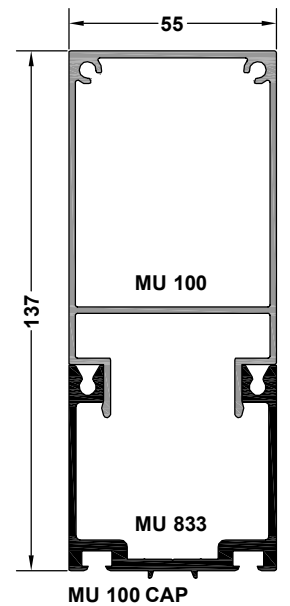
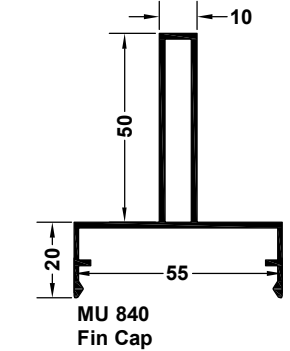
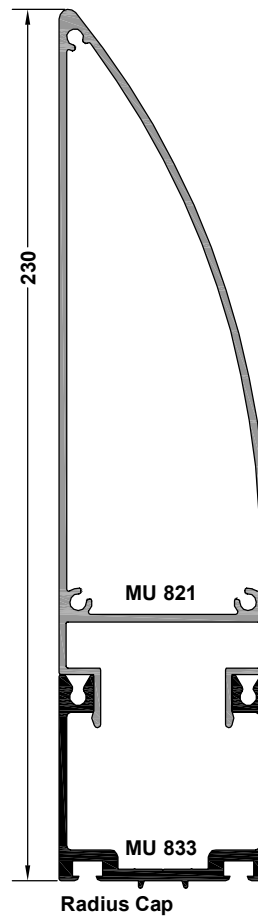
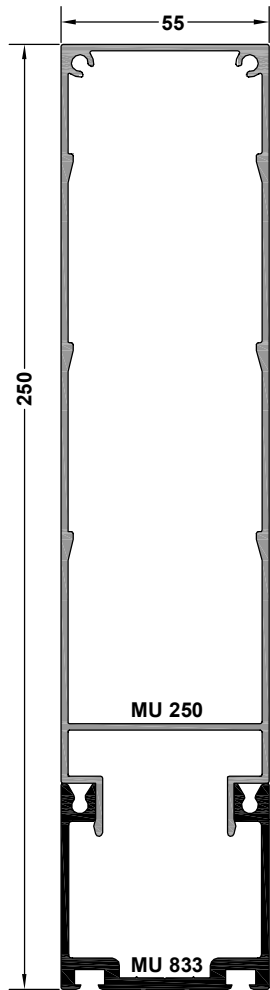
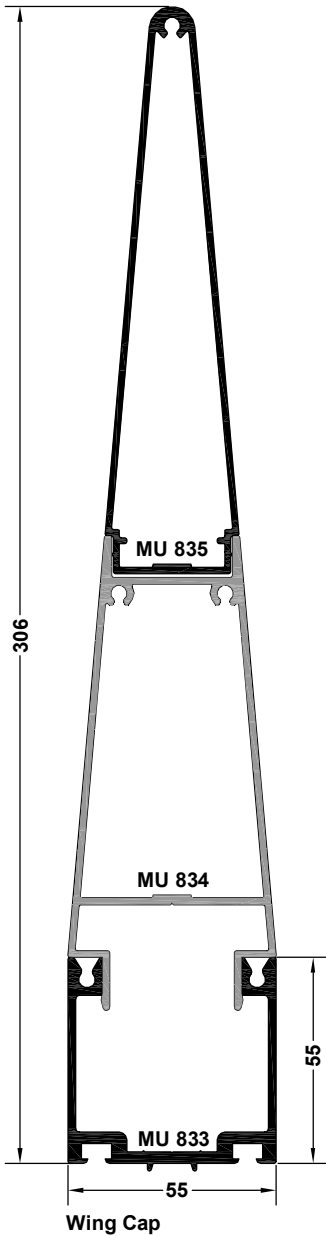
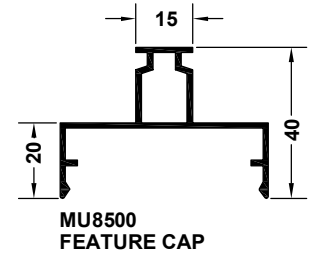
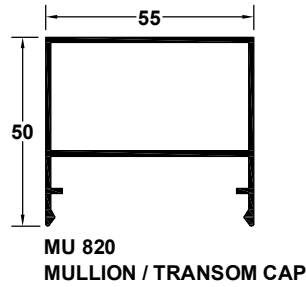
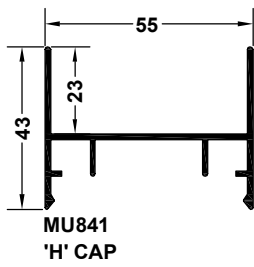
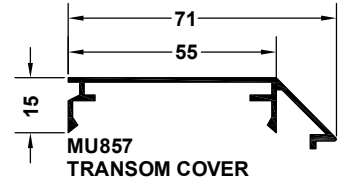
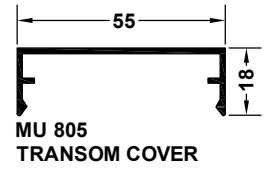
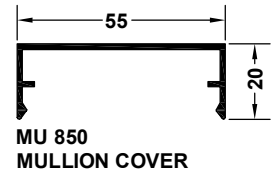
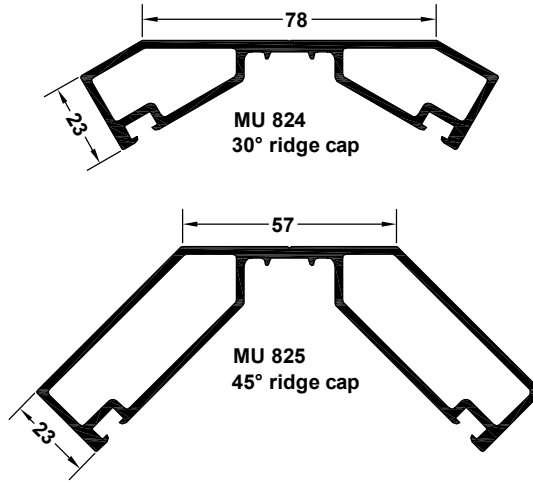
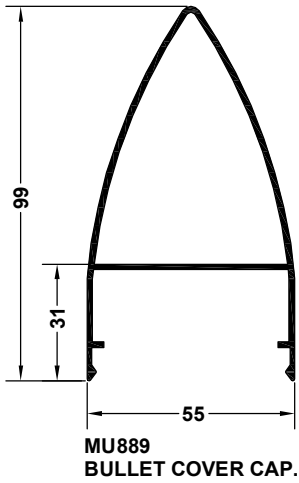

# MU 800 SERIES MULLION DRAINED SYSTEM

gaskets and accessories

Scale NTS



**G1505**  
24 / 28mm glazing -  
pressure plate gasket  
Code - CWG001

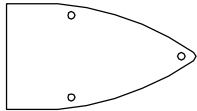

**MU899E**  
End plate for MU899 capping

**G1550**



Transom sealing/  
end gasket  
(MU 893)



**CWG 010**  
24 / 28mm glazing -  
Transom gasket

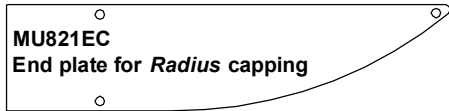

**MU821EC**  
End plate for *Radius* capping



**CWG 014**  
24 / 28mm glazing -  
Mullion gasket

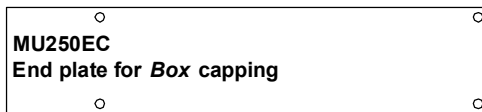

**MU250EC**  
End plate for *Box* capping



**G 1501**  
EPDM Grid  
insulator for  
24 mm units  
Code = CWA001

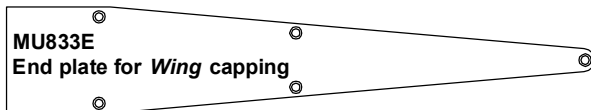

**MU833E**  
End plate for *Wing* capping



**CWATB**  
Isolator for  
28mm Units

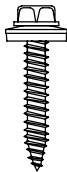

**CWA 025**  
14 x 38 hex head screw  
with bonded washer  
(28mm glazing). See  
drawing 1.1.09 & 10

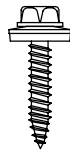

**CWA 028**  
14 x 32 hex head screw  
with bonded washer  
(6 - 24mm glazing). See  
drawing 1.1.09 & 10



**CWA 030**  
No. 8 x 19 tamper  
proof transom screw

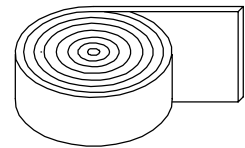

**Butyl tape**  
50mm - CWG003  
100mm - CWG004  
150mm - CWG005

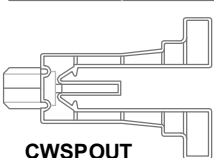
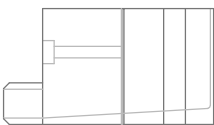

**CWSPOUT**  
Drainage  
spout



**CWA 031**  
Drill bit to suit  
transom screw



**Stepped drill bit**  
T 114

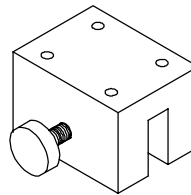

**Mullion Jig**  
T112

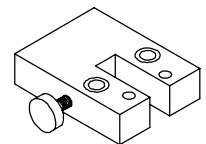

**T 113**  
Transom Jig

Heads for punch tool

Small

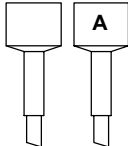

Transom drained  
holes for cleats

Medium

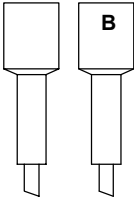

Mullion drained  
holes for cleats

Large

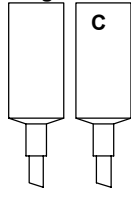

Mullion drained  
holes for transom  
fixing screws  
(Oval head)

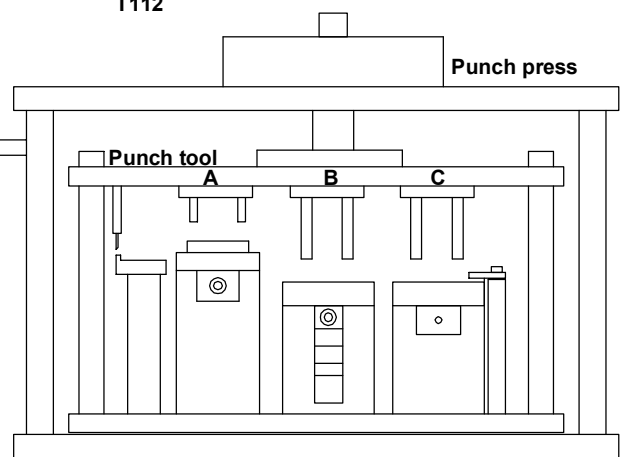
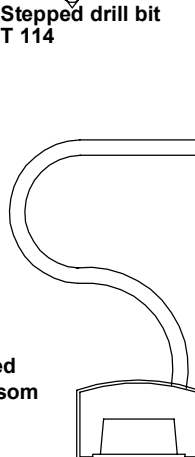

Punch press for curtain wall transoms

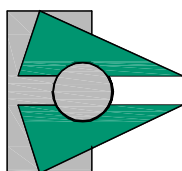

# MU 800 SERIES MULLION DRAINED SYSTEM

## Accessories

Scale NTS

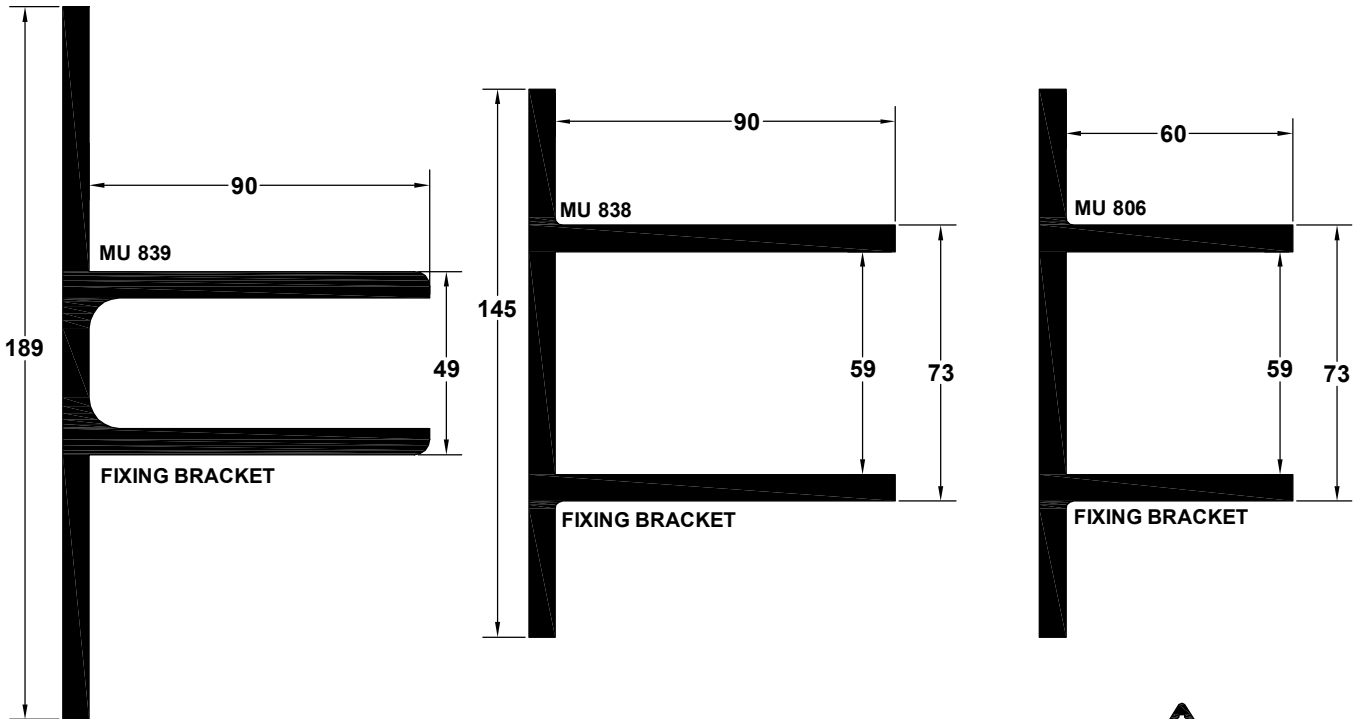

**MU 875**  
11.5mm GLAZING  
ADAPTER

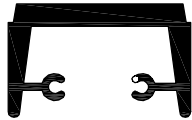

**MU 844 Cleat (Bar length)**  
CWA019 - 57mm cleat (MU883)  
CWA020 - 72mm cleat (MU896)  
CWA021 - 101mm cleat (MU894 & MU899)

(For transom spans over 2.5m and/or glass weight is more than 100Kg's, use support cleats)

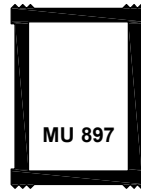

**MU 897**  
lxx = cm4  
Mullion joint sleeve  
(to suit MU 892)

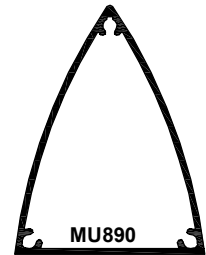

**MU 890**  
Joint sleeve to  
suit MU 889



**MU 848**  
6mm GLAZING  
ADAPTER

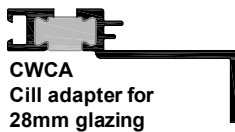

**CWCA**  
Cill adapter for  
28mm glazing

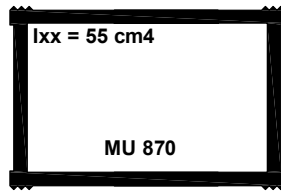

lxx = 55 cm4

**MU 870**

Mullion joint sleeve  
(to suit MU 895)

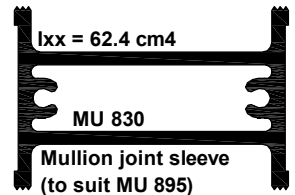

lxx = 62.4 cm4

**MU 830**

Mullion joint sleeve  
(to suit MU 895)



**MU 868**  
14.5mm GLAZING  
ADAPTER

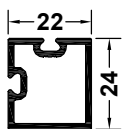

**CWAC**  
channel closer to  
suit 24mm units

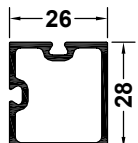

**CWAC28**  
channel closer to suit  
28mm units

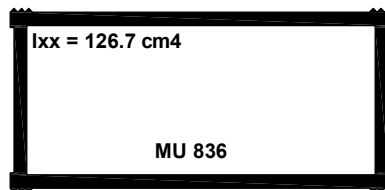

lxx = 126.7 cm4

**MU 836**

Mullion joint sleeve  
(to suit MU 882)

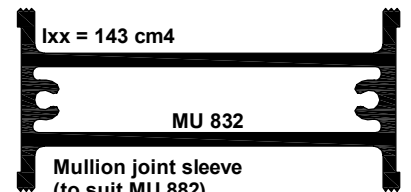

lxx = 143 cm4

**MU 832**

Mullion joint sleeve  
(to suit MU 882)

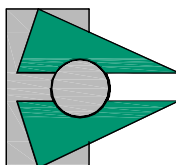

# MU 800 SERIES MULLION DRAINED SYSTEM

Brackets

Scale NTS

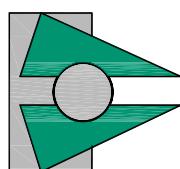
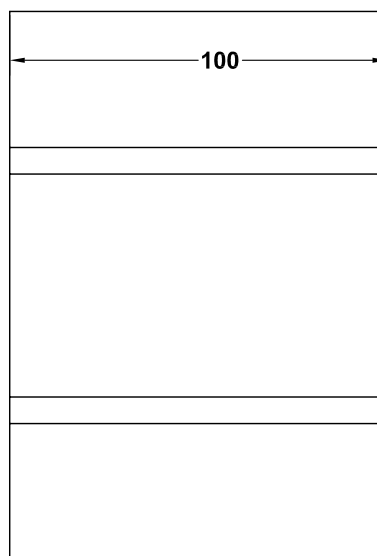
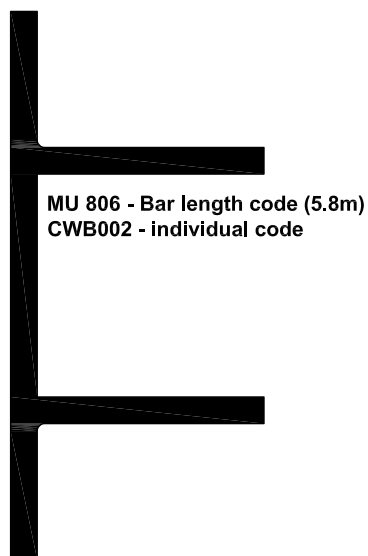
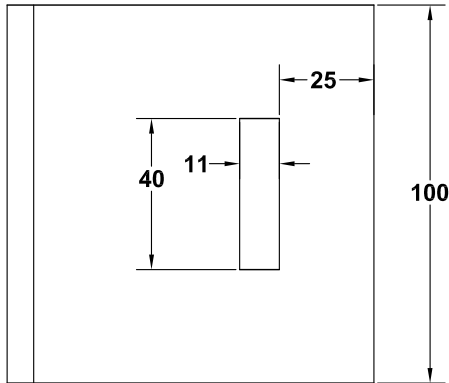
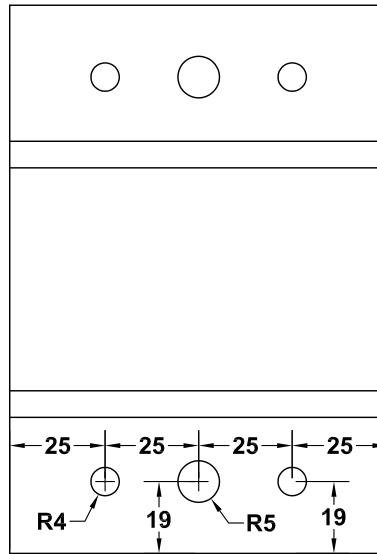
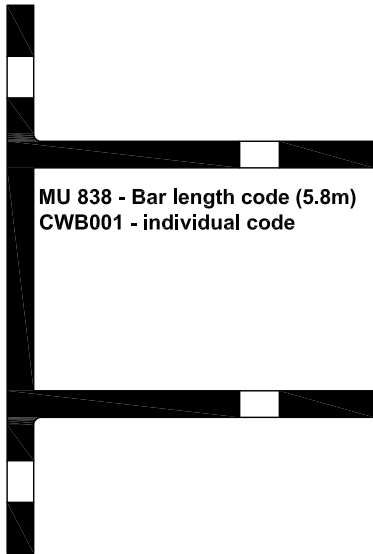



# MU 800 SERIES MULLION DRAINED SYSTEM

lxx values for mullions with sleeve  
scale NTS

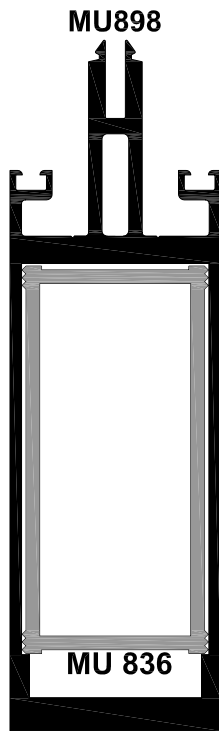

lxx 868 cm4

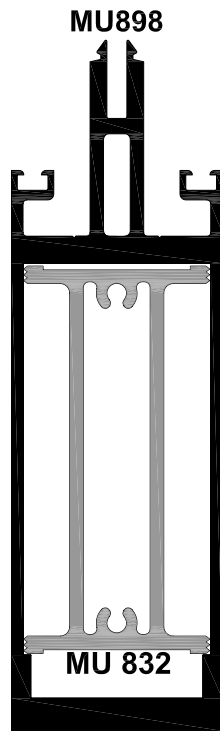

lxx 888 cm4

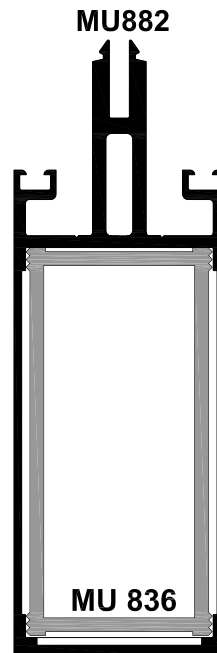

lxx 525 cm4

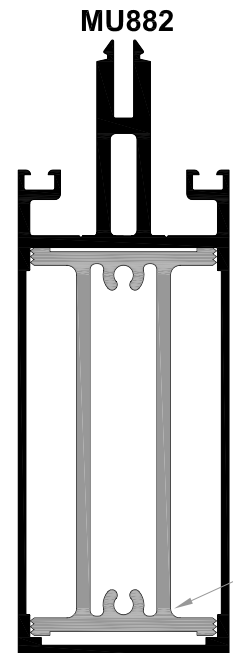

lxx 583 cm4

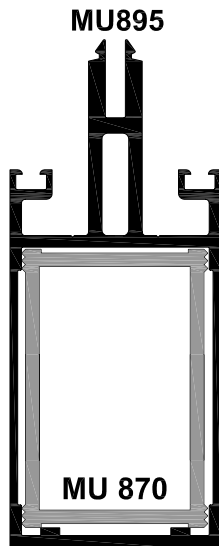

lxx 285 cm4

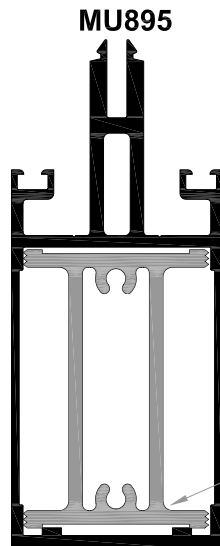

lxx 322 cm4

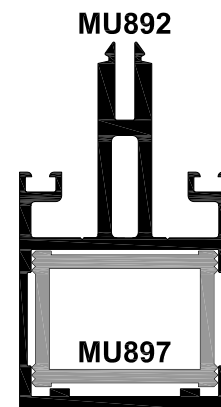

lxx 134.5 cm4

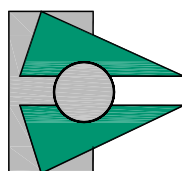

# MU 800 SERIES MULLION DRAINED SYSTEM

## Profile assembly

### Scale NTS

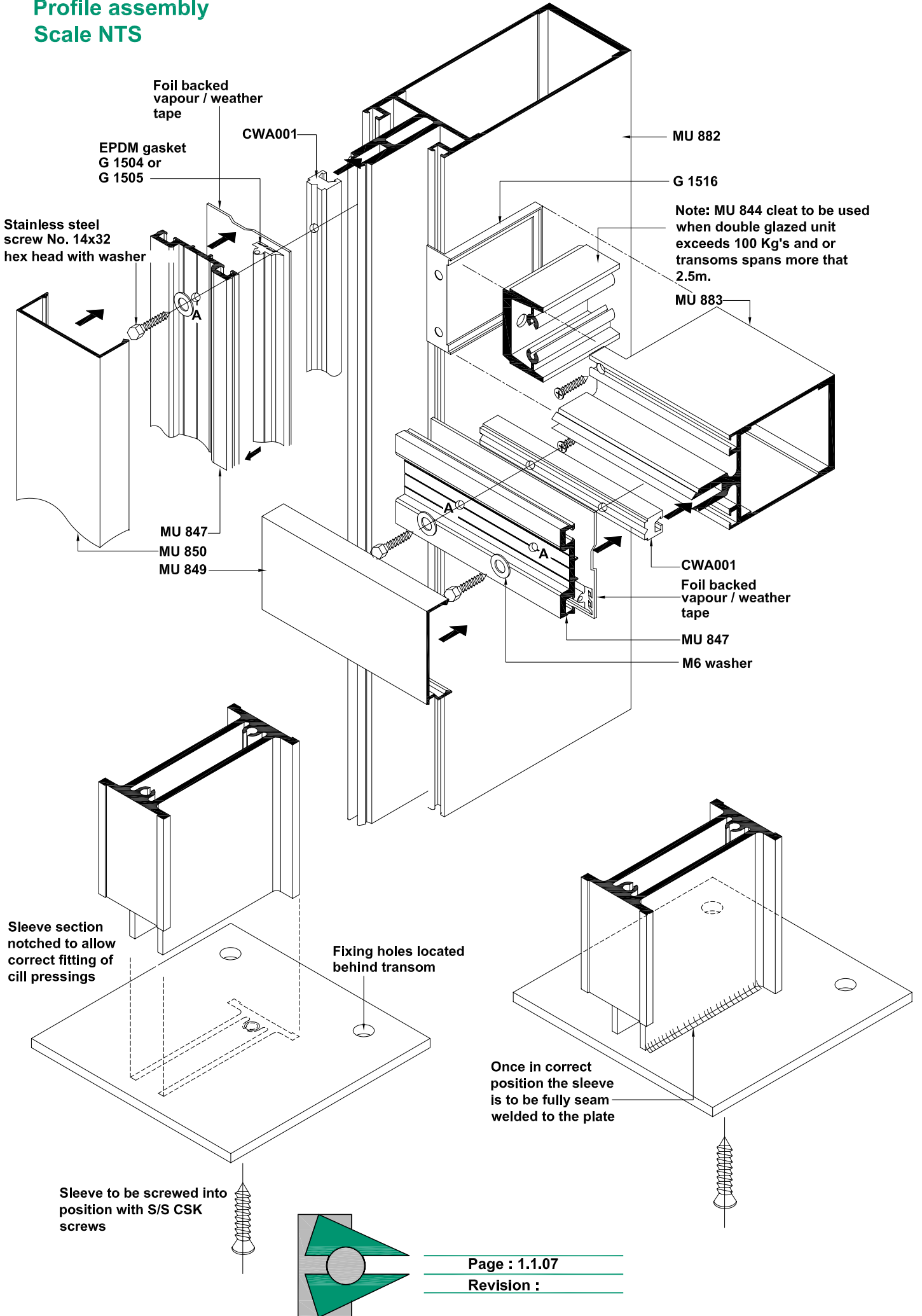

# MU 800 SERIES MULLION DRAINED SYSTEM

## Capping assembly

### Scale NTS

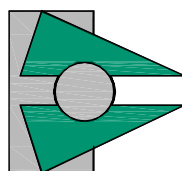
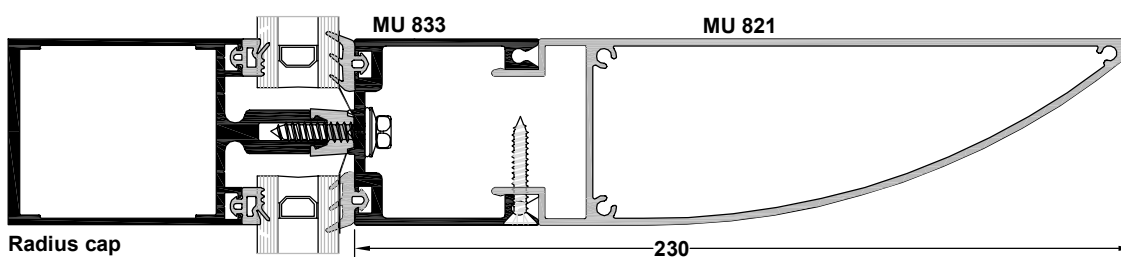
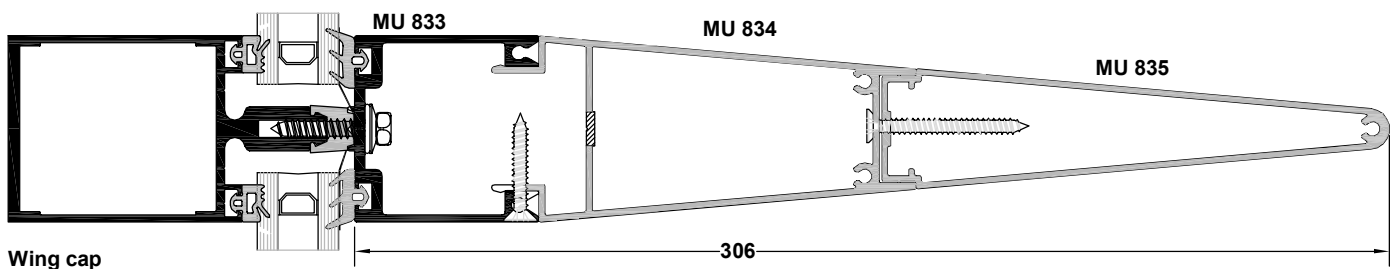
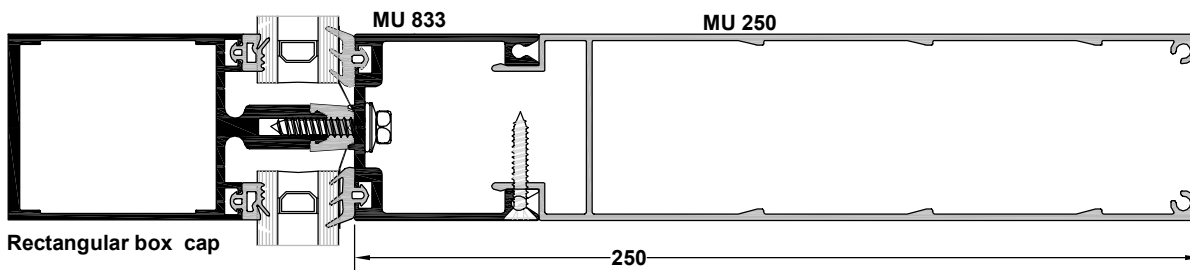
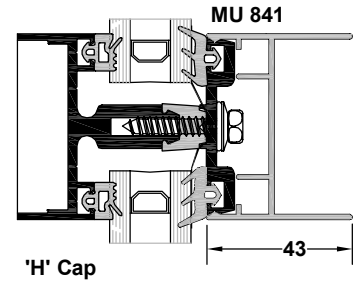
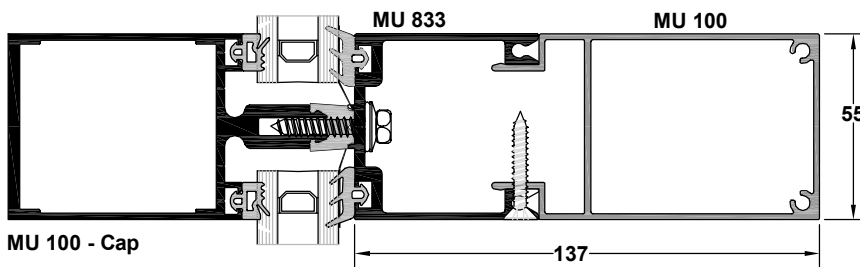
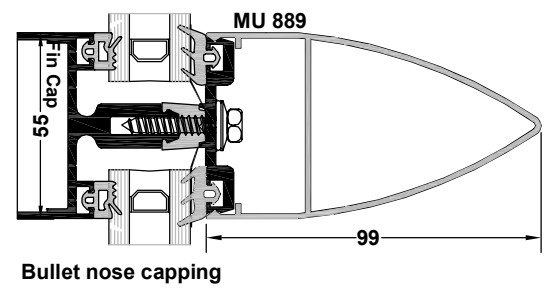
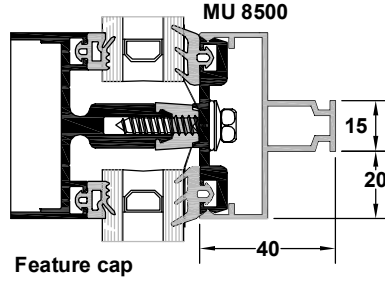
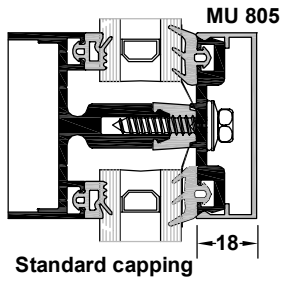
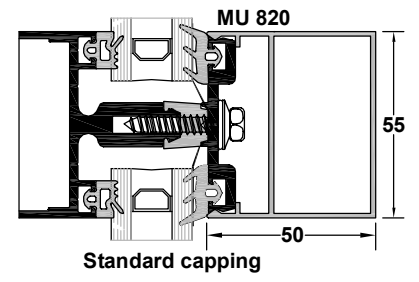
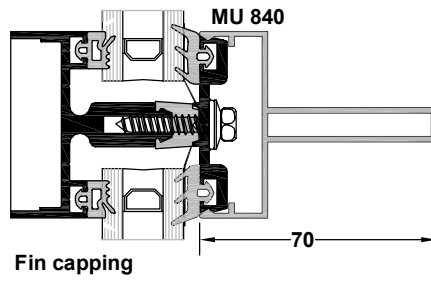
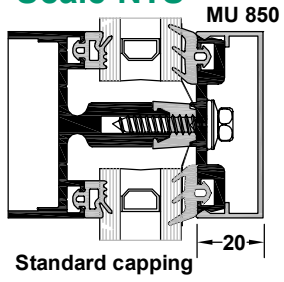

# MU 800 SERIES MULLION DRAINED SYSTEM

Mullion assembly for double / single glazing

Scale NTS

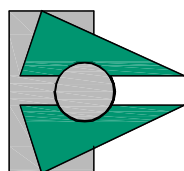
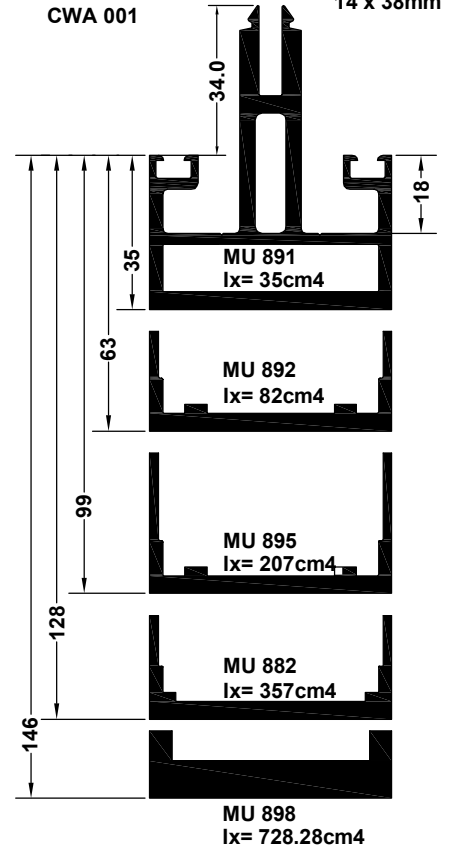
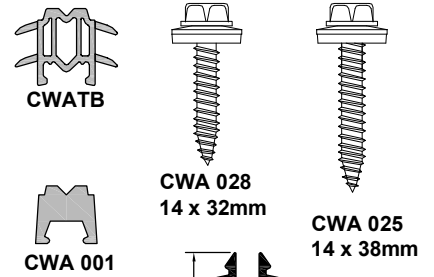
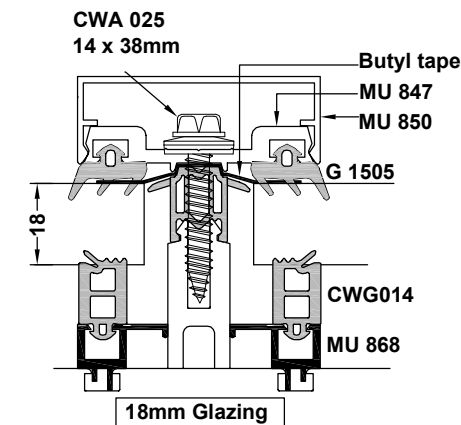
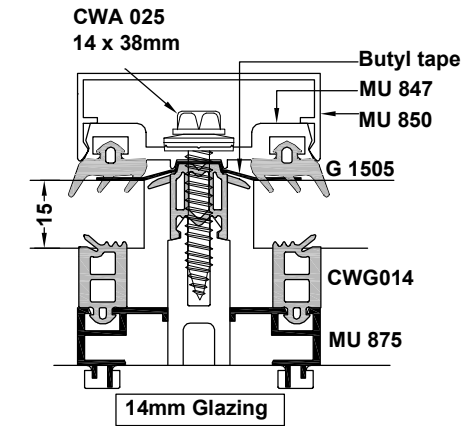
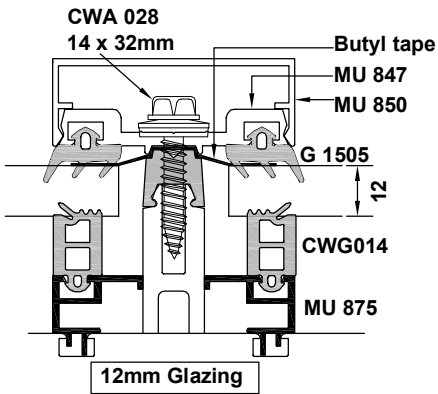
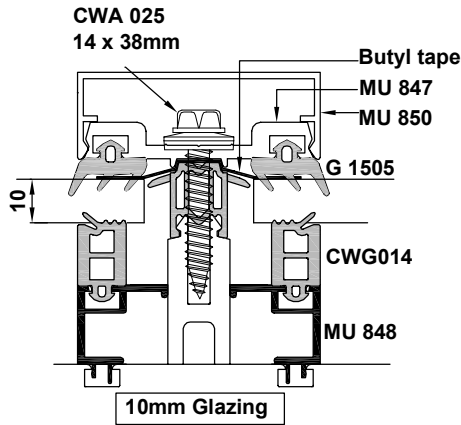
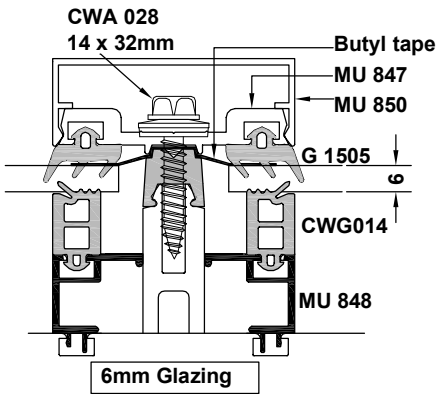
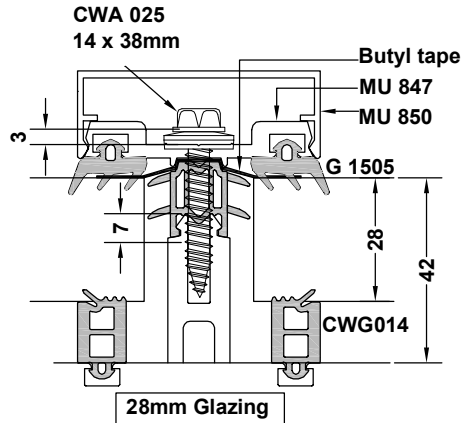
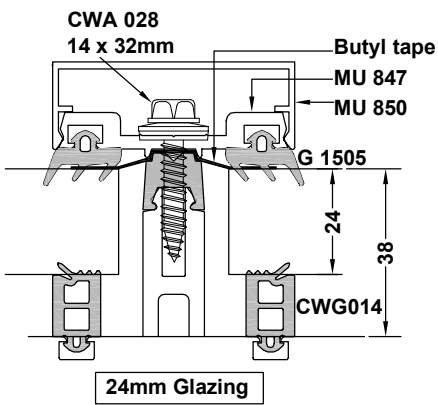

# MU 800 SERIES MULLION DRAINED SYSTEM

Transom assembly for double / single glazing

Scale NTS

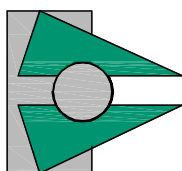
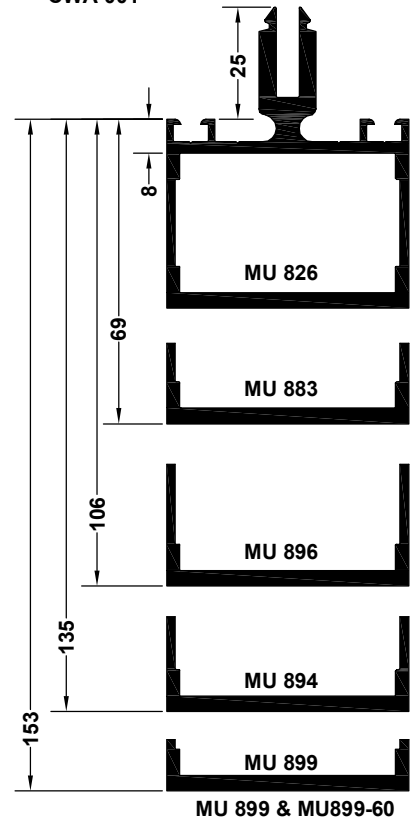
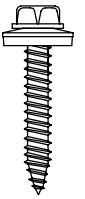
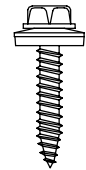
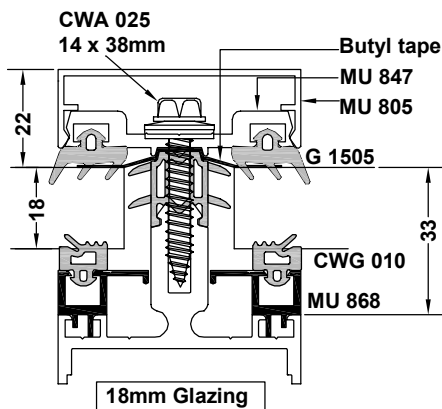
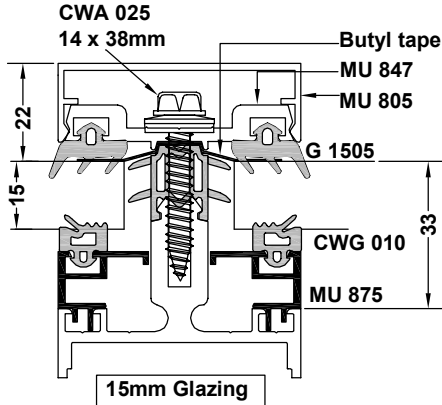
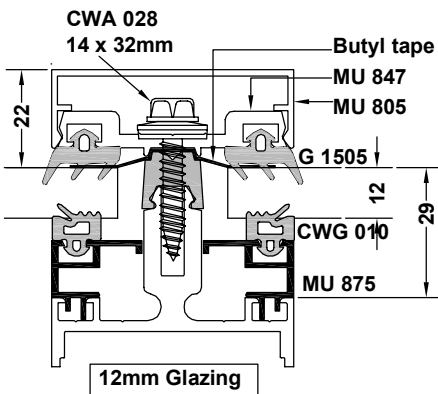
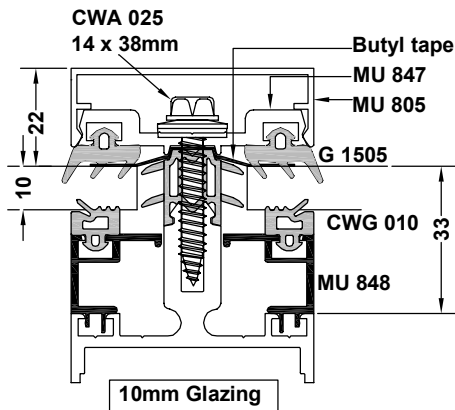
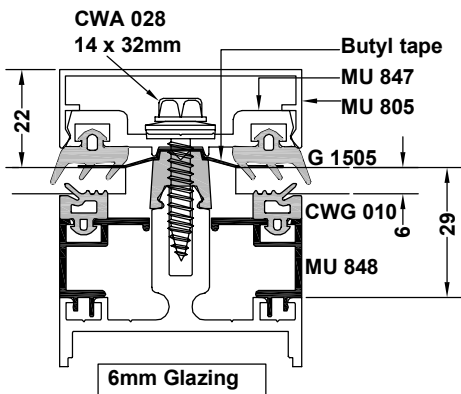
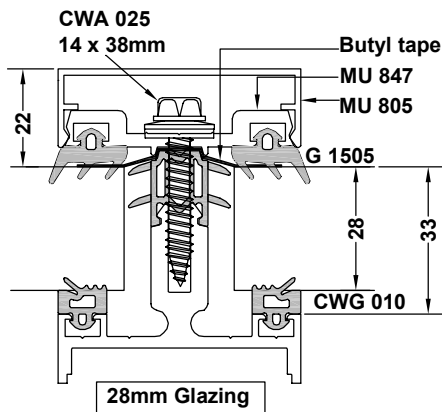
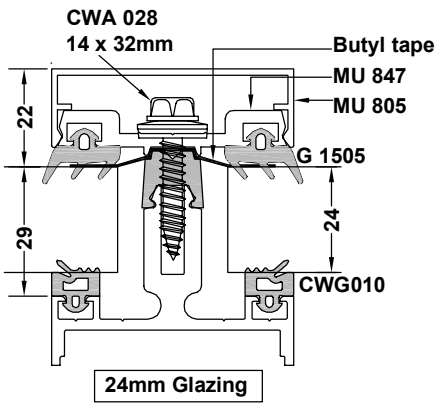

# MU 800 SERIES MULLION DRAINED SYSTEM

Profile applications

Scale NTS

**Curtain  
walling**

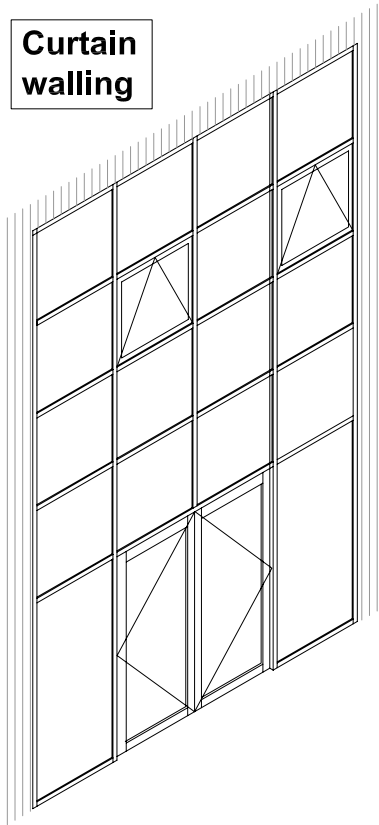

**Sloped glazing**

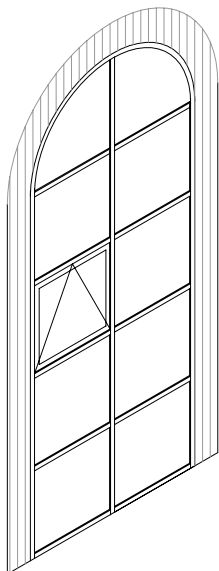
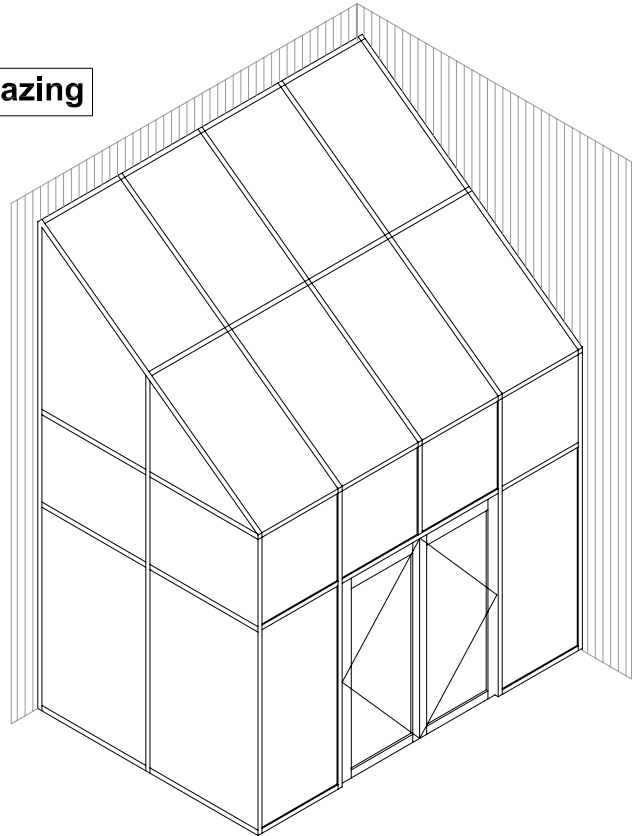

**Arched heads**

**Rooflights**

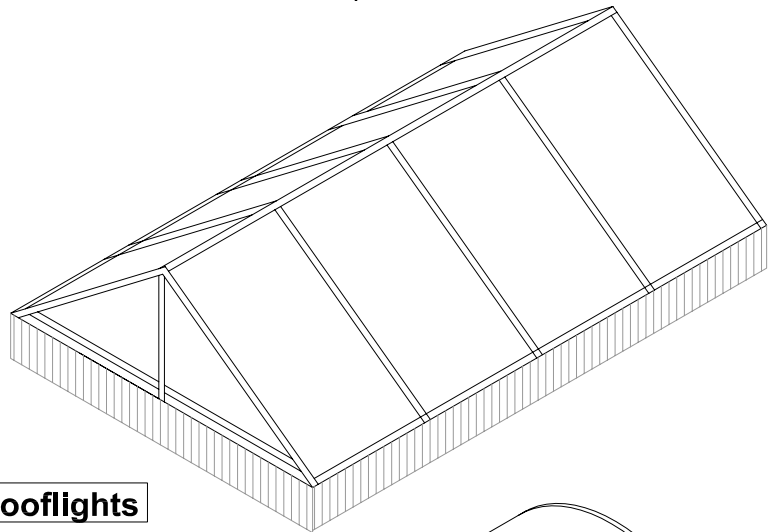

**Rooflights**

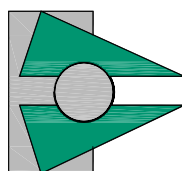
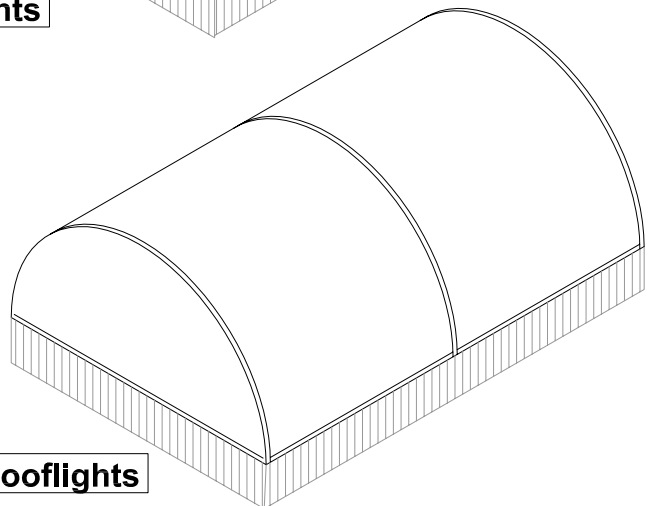

# MU 800 SERIES MULLION DRAINED SYSTEM

Typical head detail

Scale 1:2

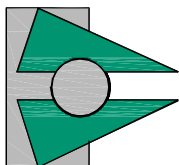
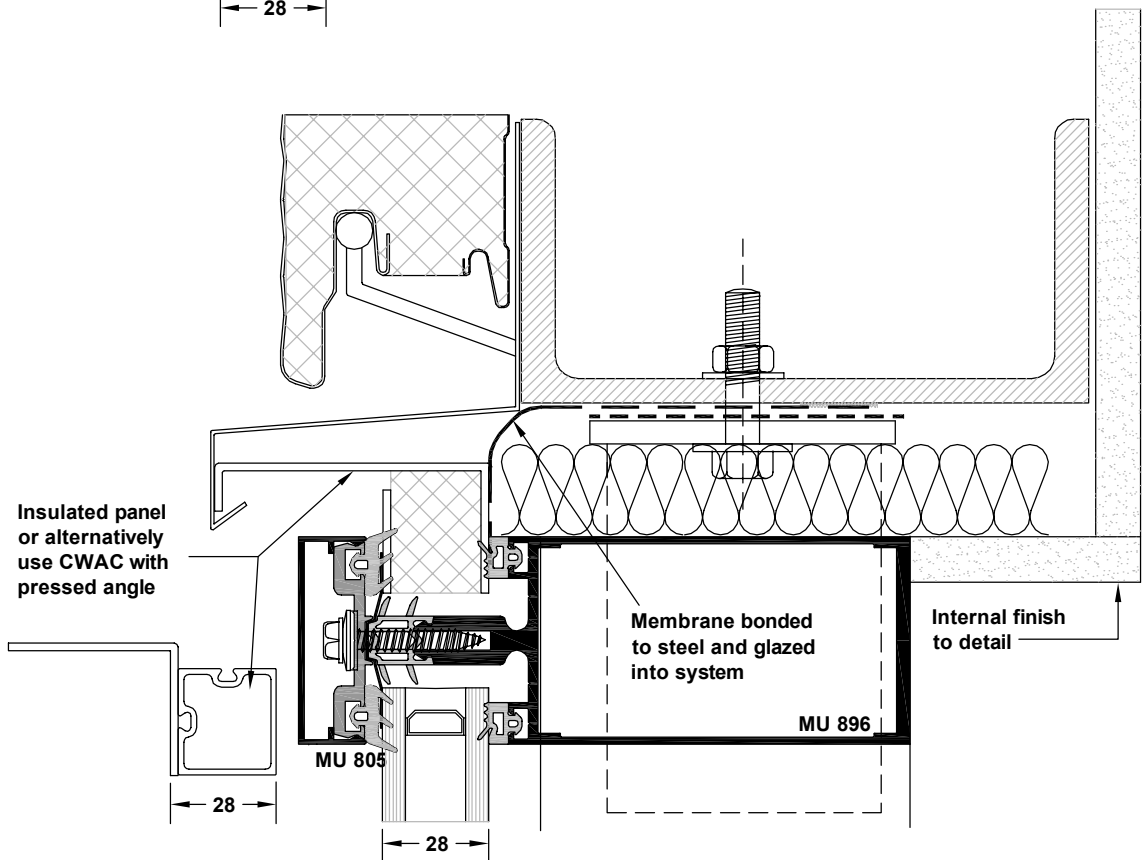
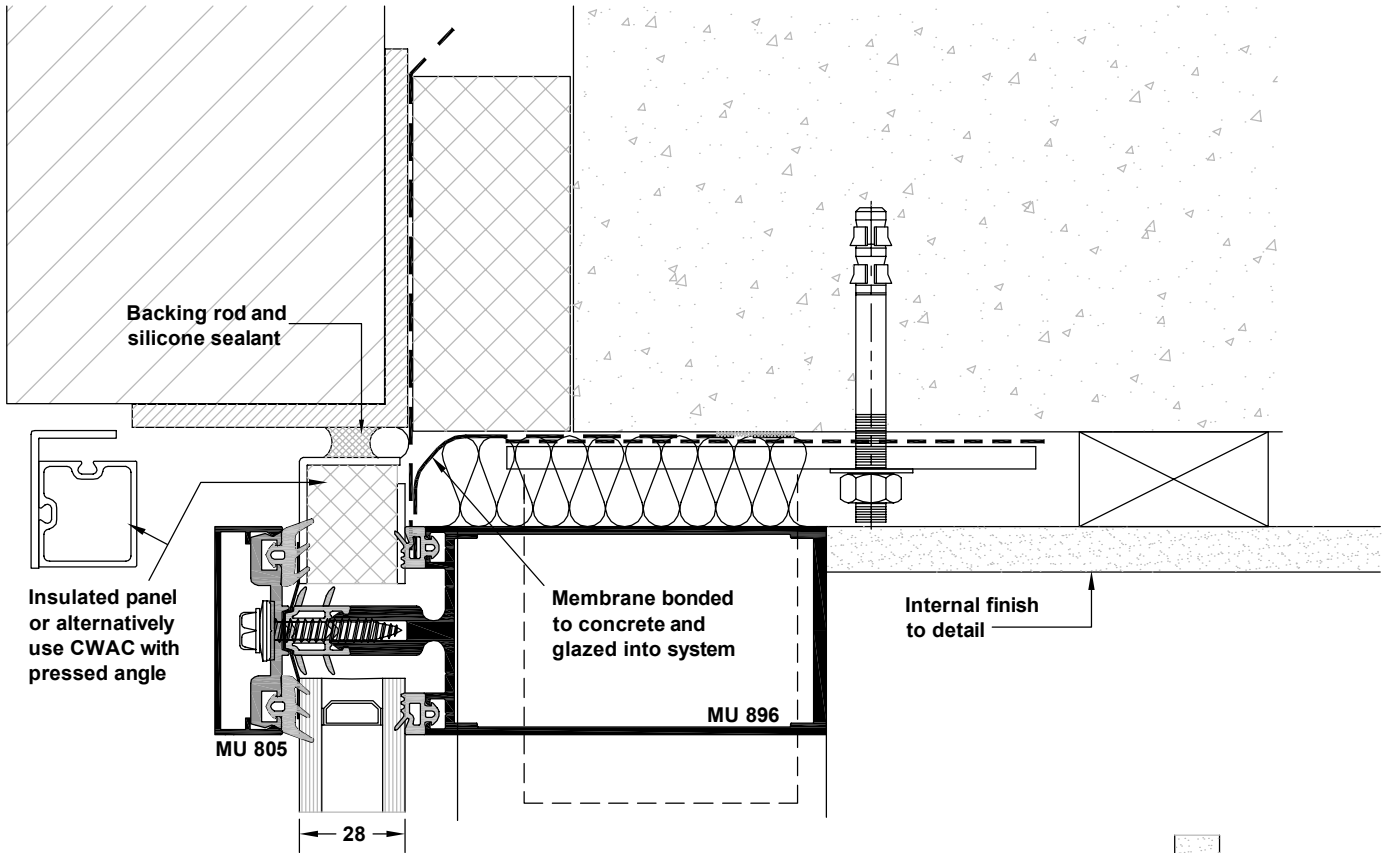

# MU 800 SERIES MULLION DRAINED SYSTEM

Typical head detail

Scale 1:2

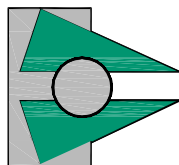
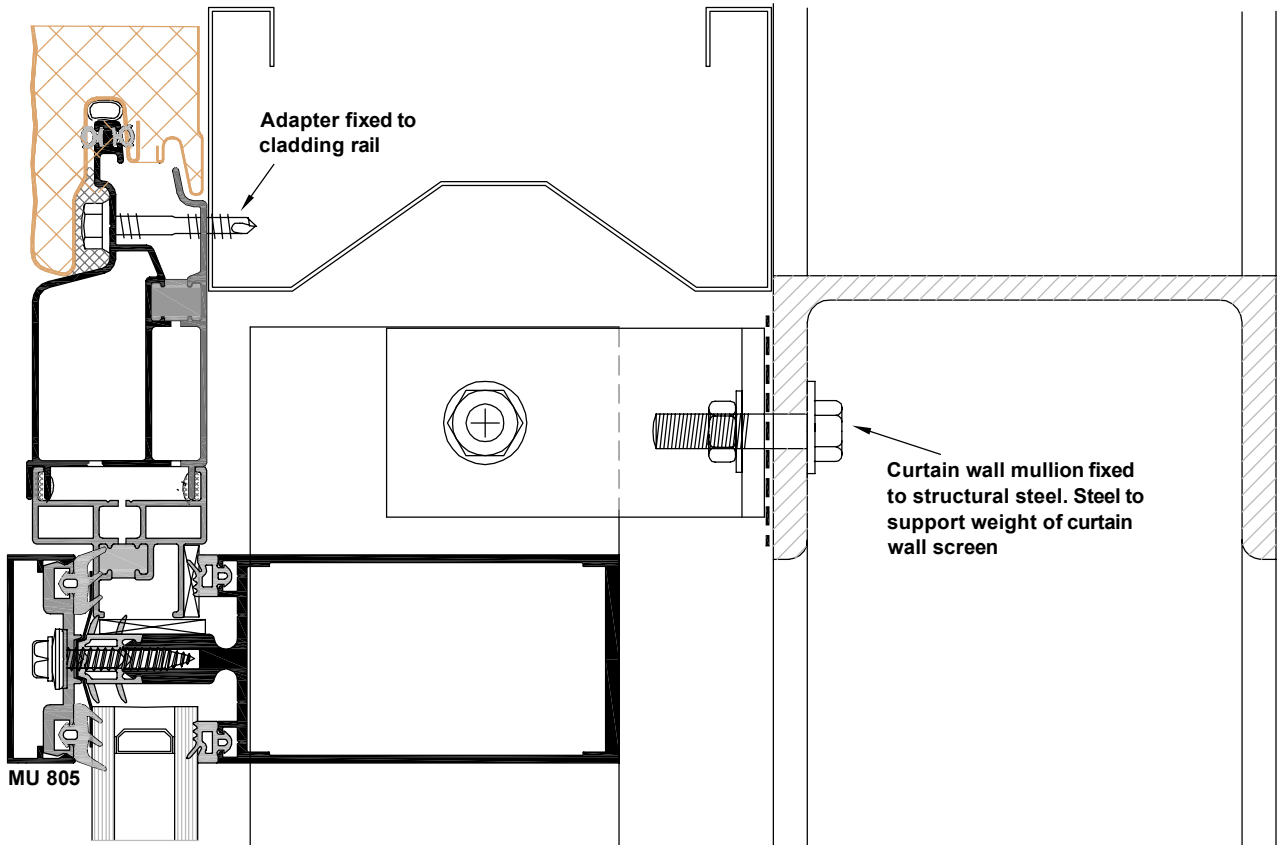
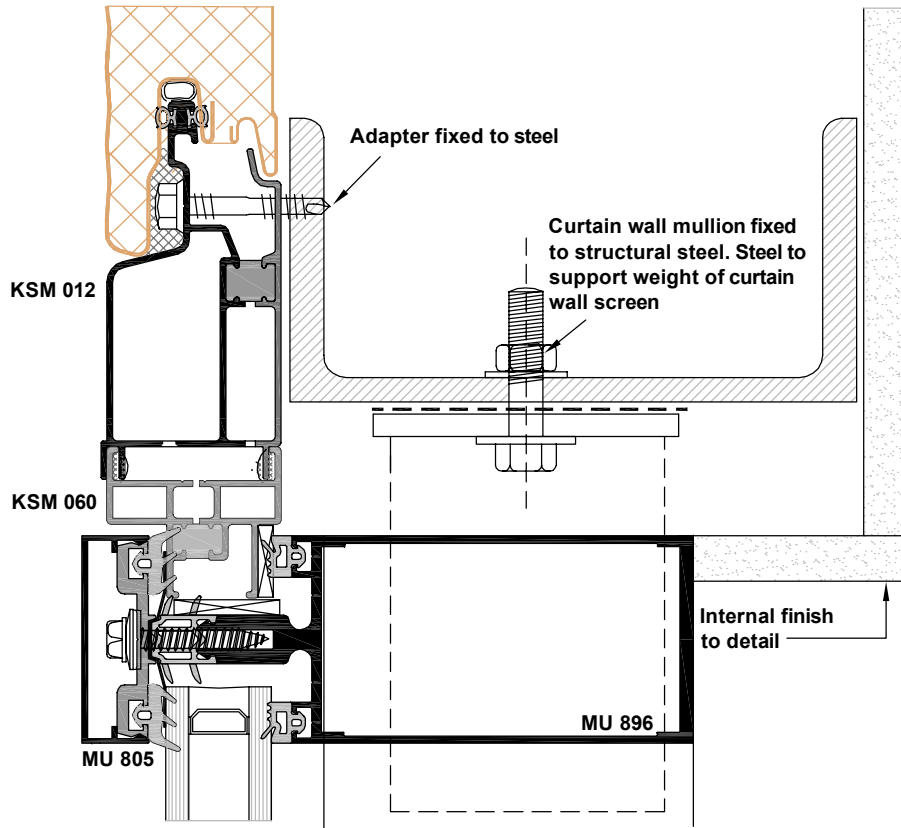



# MU 800 SERIES MULLION DRAINED SYSTEM

Typical cill detail

Scale 1:2

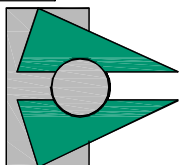
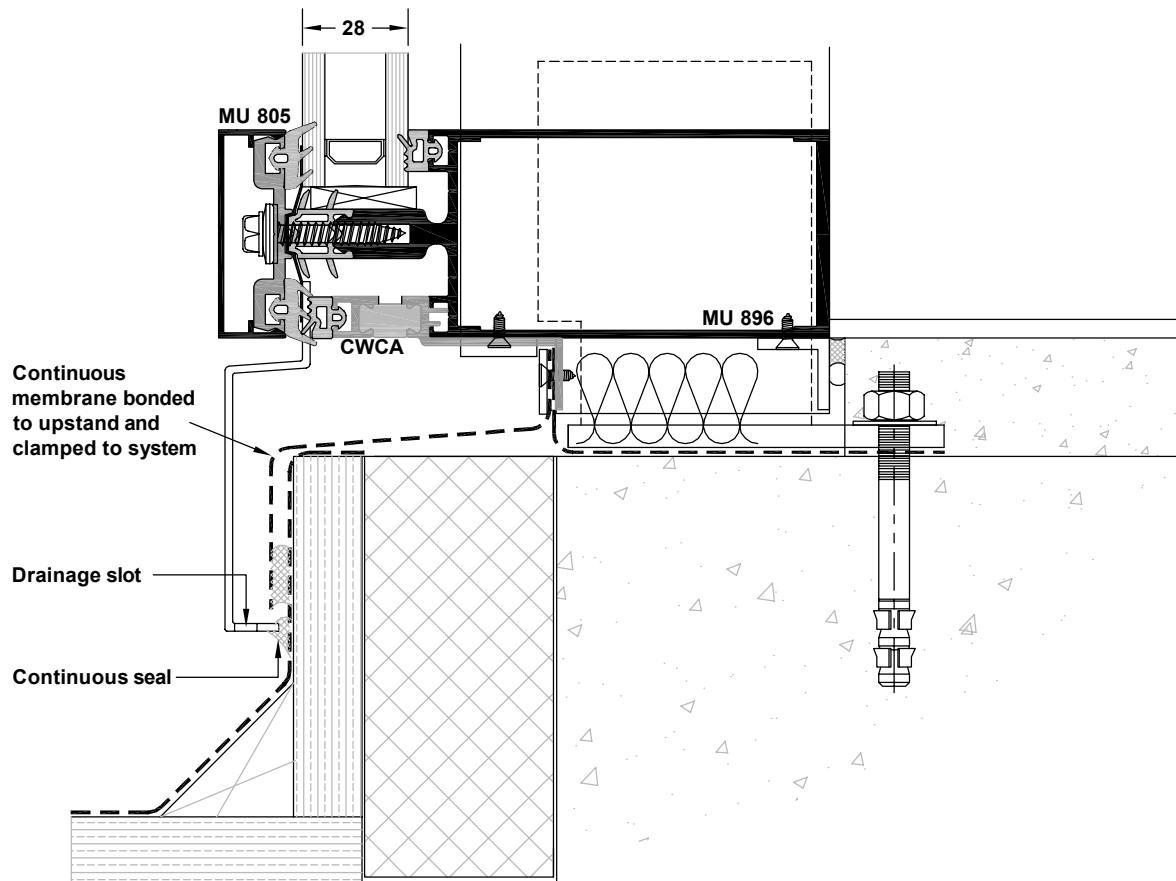
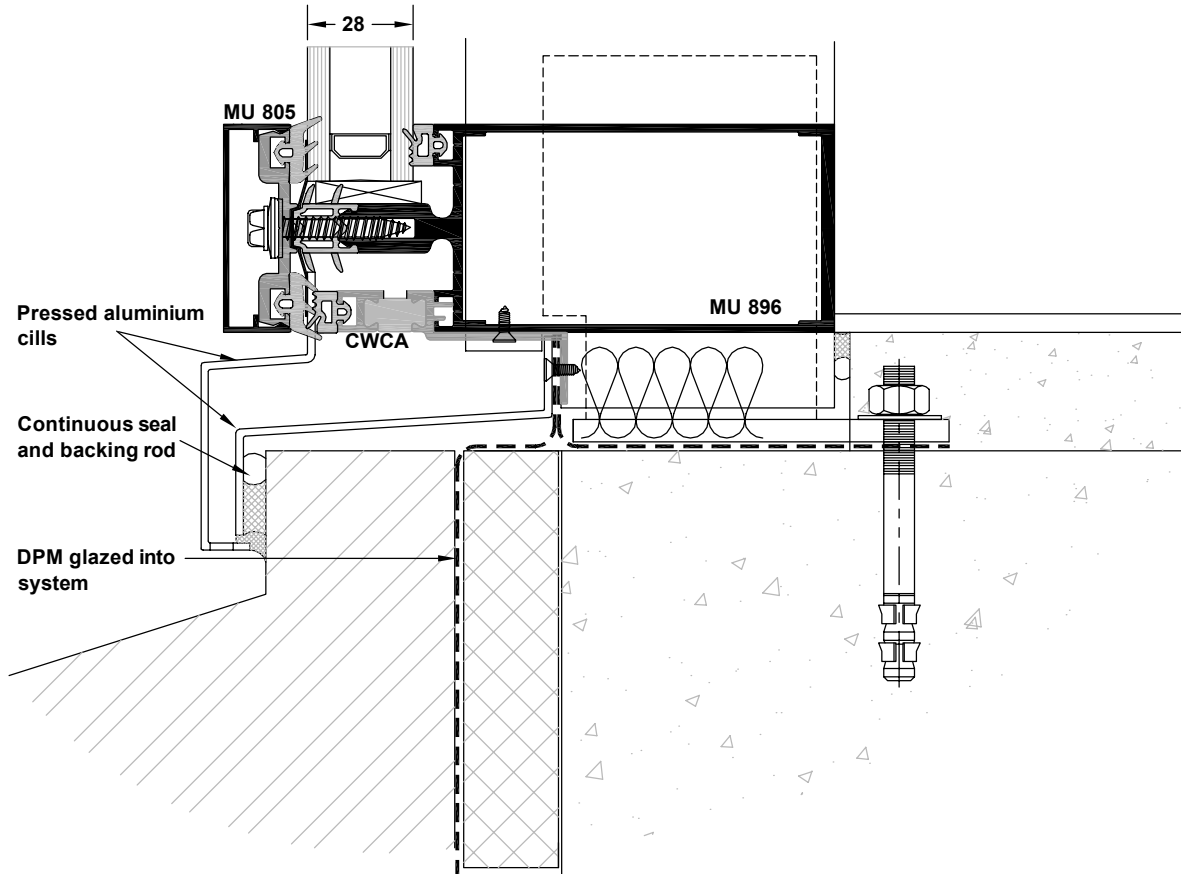

# MU 800 SERIES MULLION DRAINED SYSTEM

Typical fixing detail

Scale 1:2

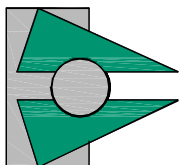
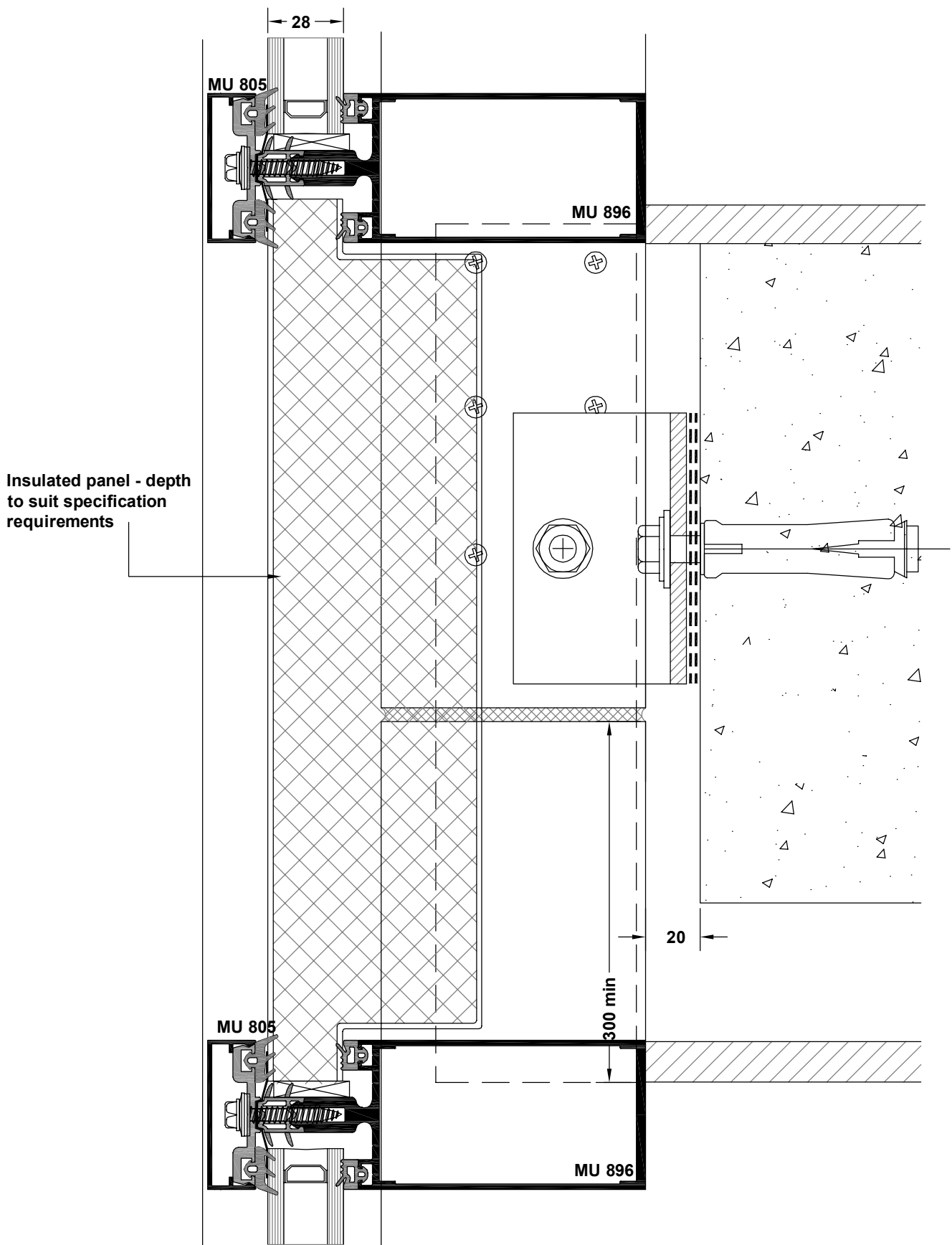

# MU 800 SERIES MULLION DRAINED SYSTEM

Typical fixing detail

Scale 1:2

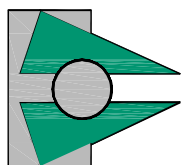
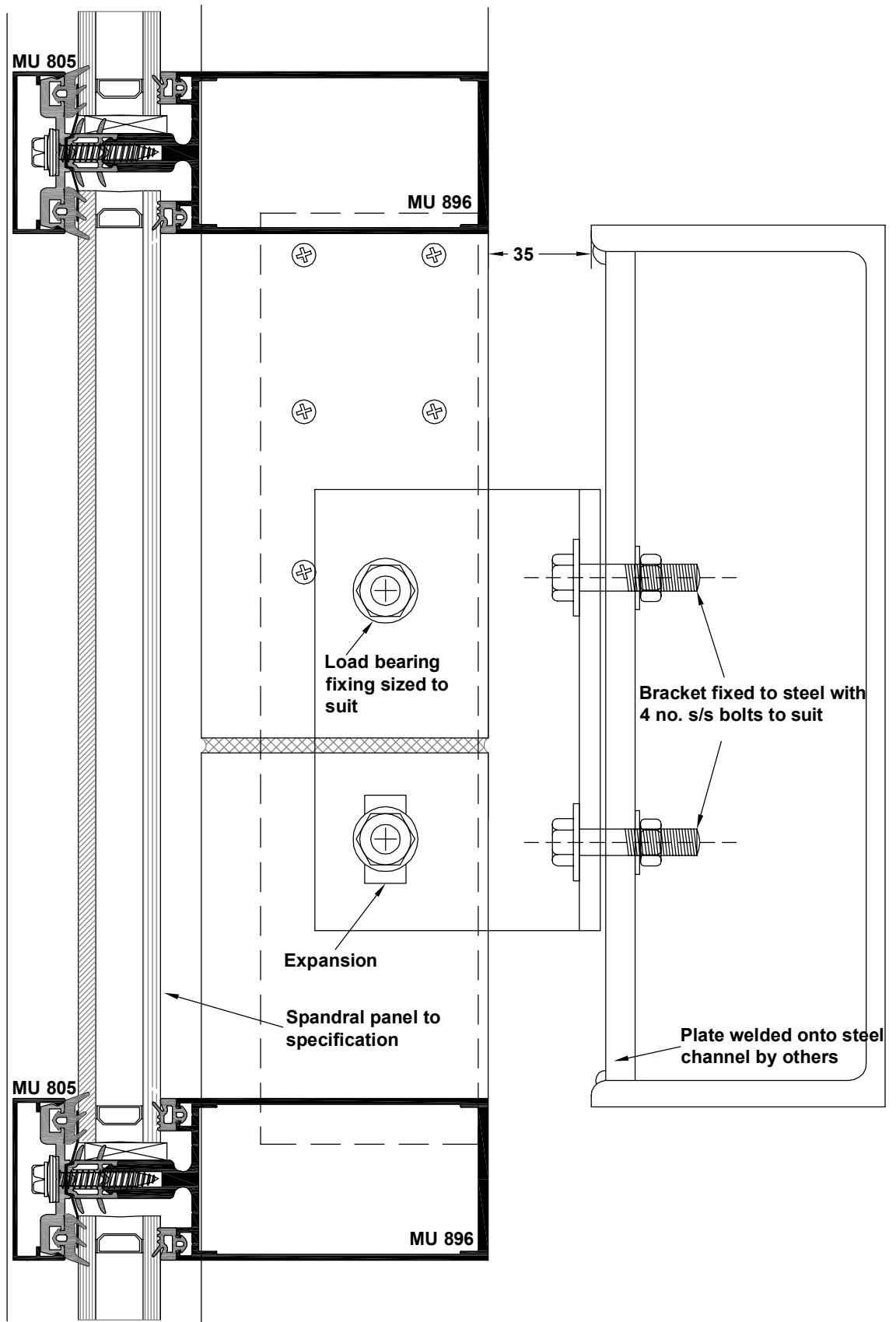

# MU 800 SERIES MULLION DRAINED SYSTEM

Typical vent detail - 24mm glazing

Scale 1:2

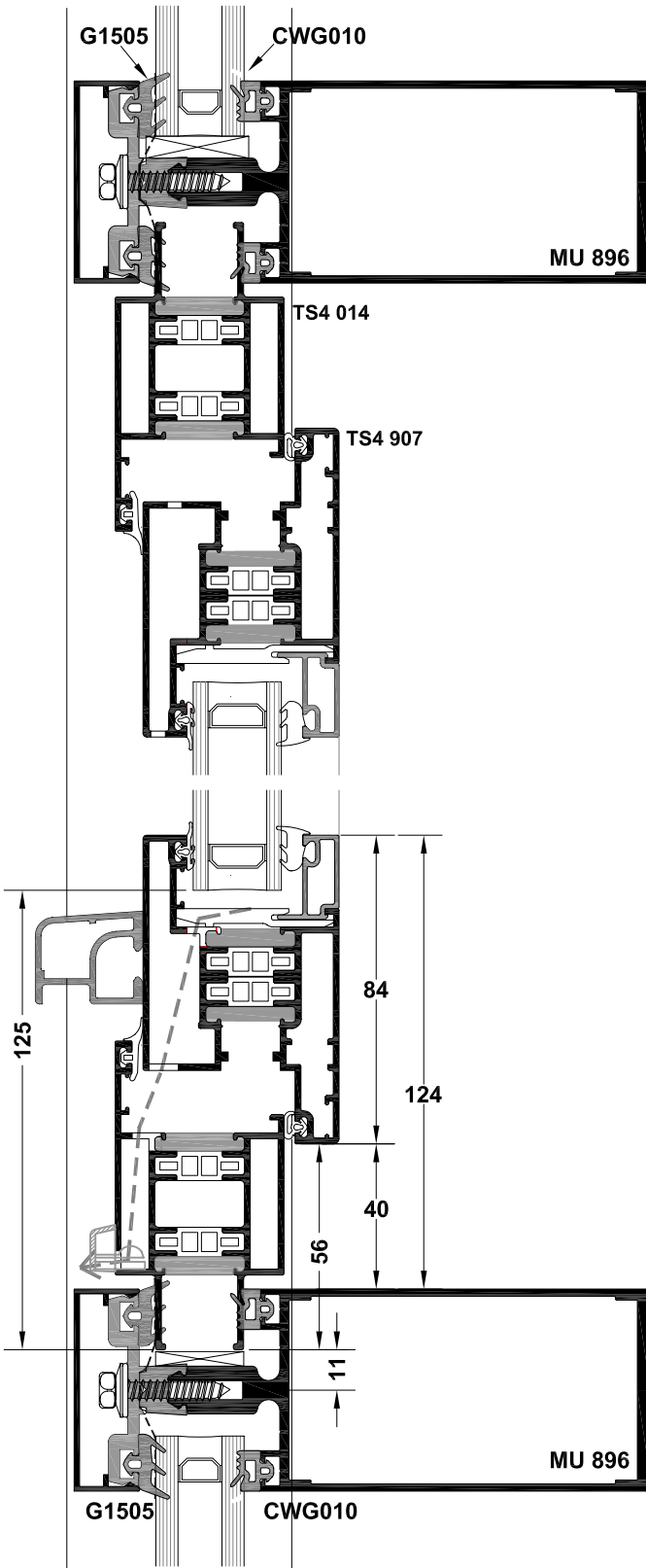

**TS46 tilt and turn into C/W**

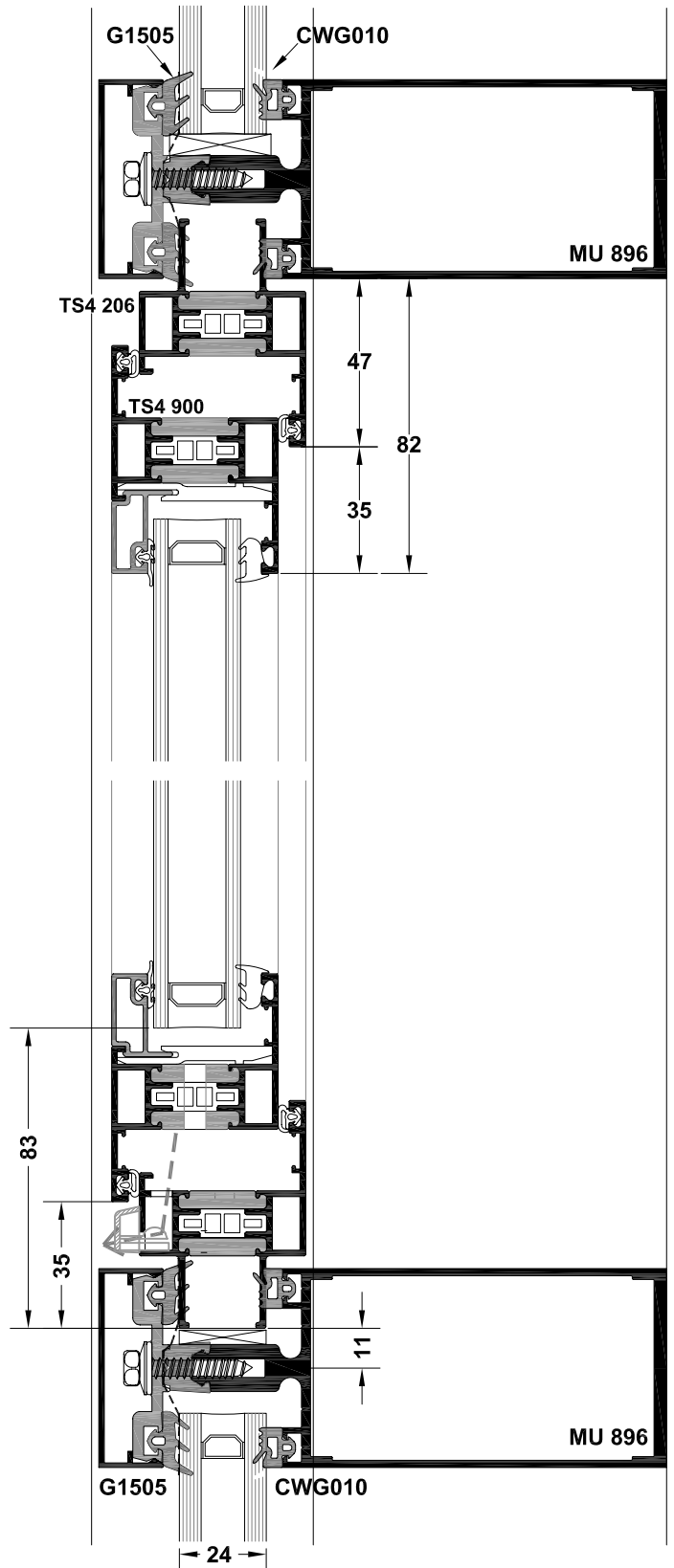

**TS46 casement into C/W**

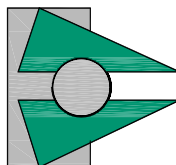

# MU 800 SERIES MULLION DRAINED SYSTEM

Concealed vent

Scale 1:2

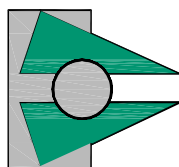
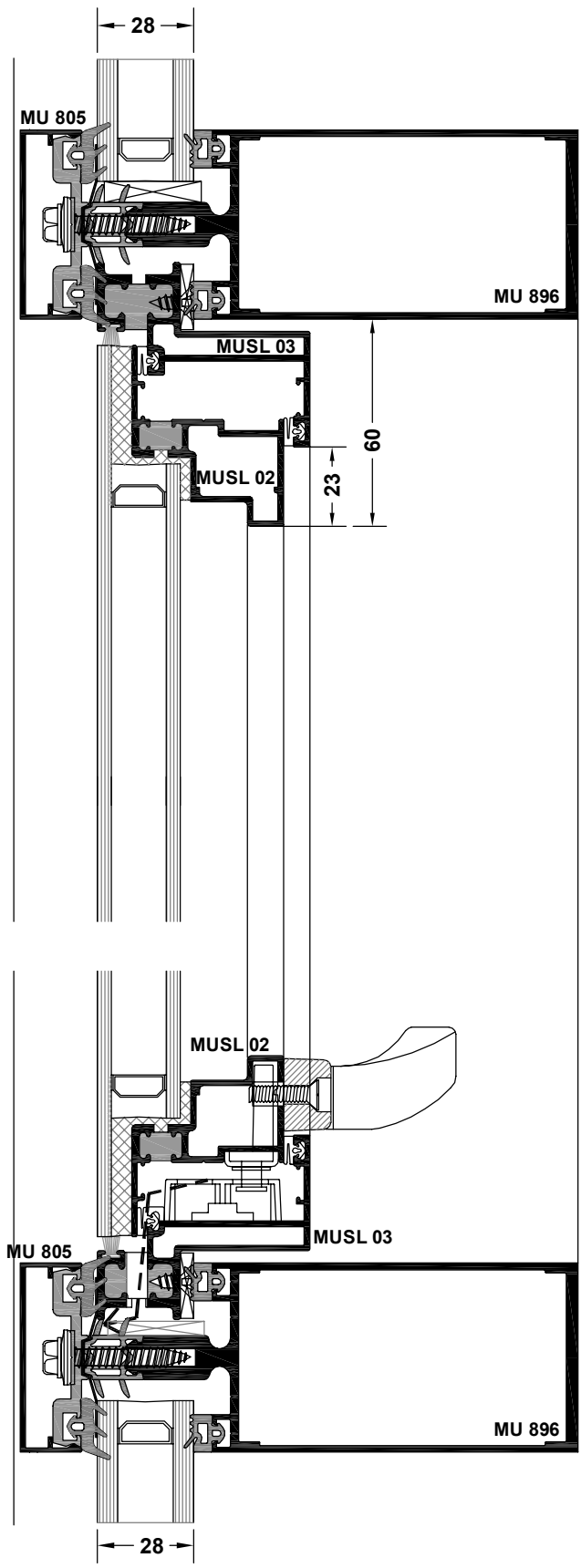
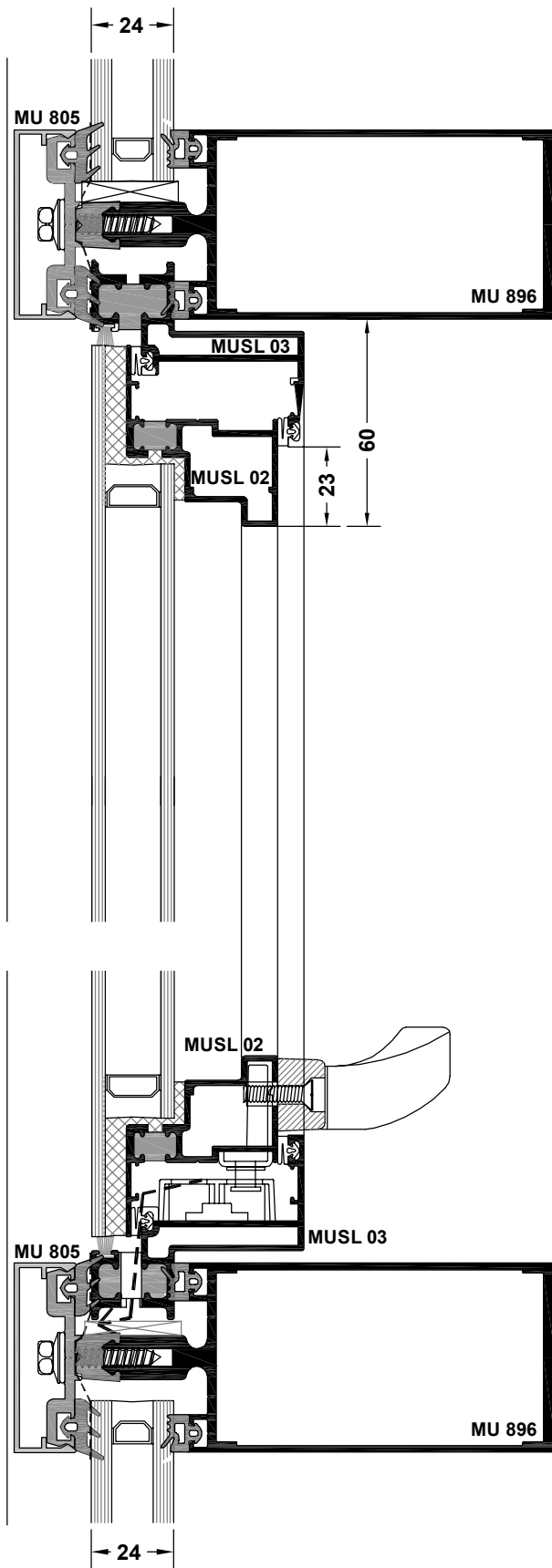

# MU 800 SERIES MULLION DRAINED SYSTEM

Typical vent detail - 28mm glazing

Scale 1:2

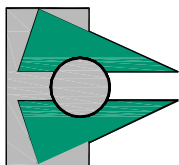
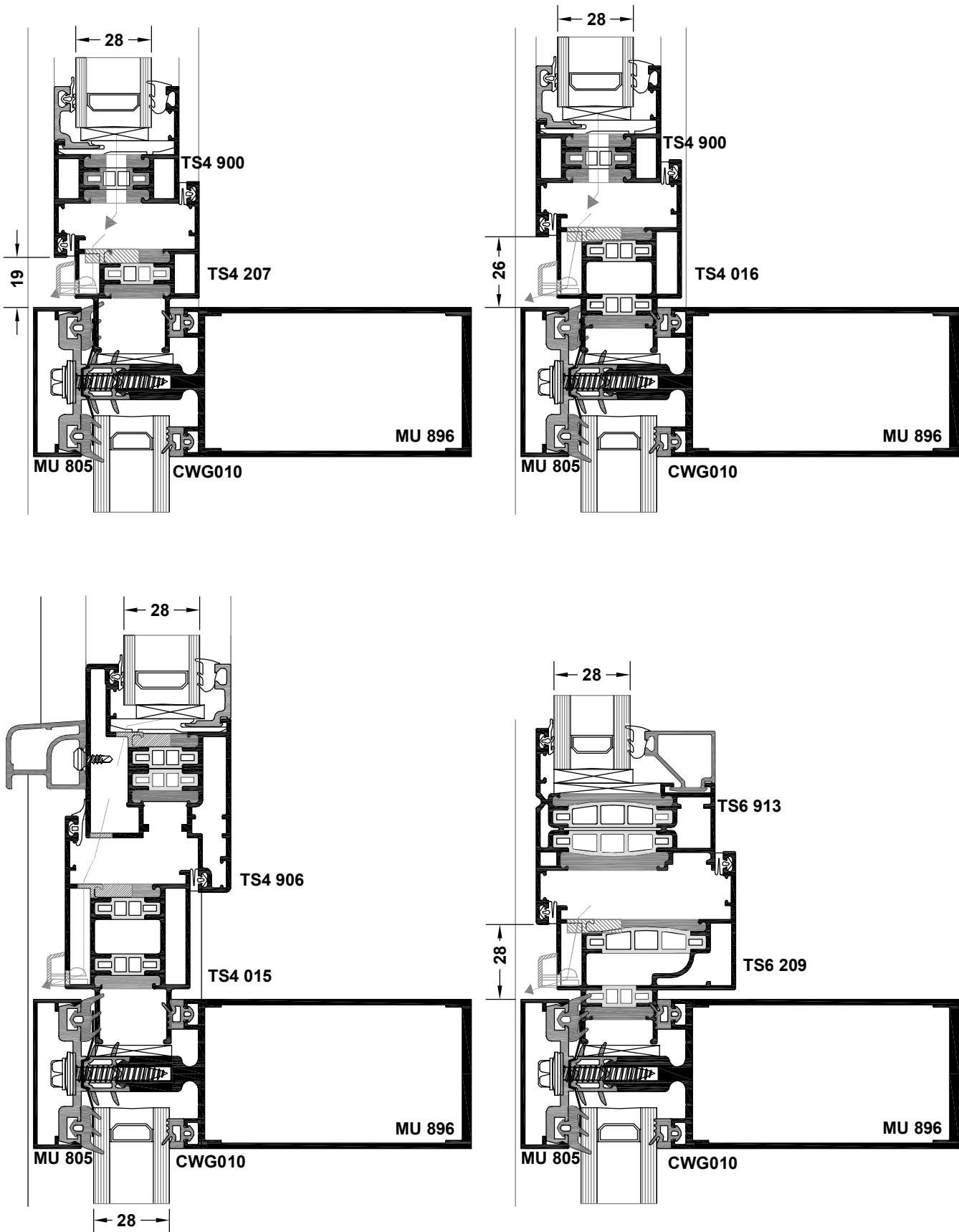

# MU 800 SERIES MULLION DRAINED SYSTEM

Typical door head detail

Scale 1:2

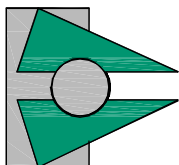
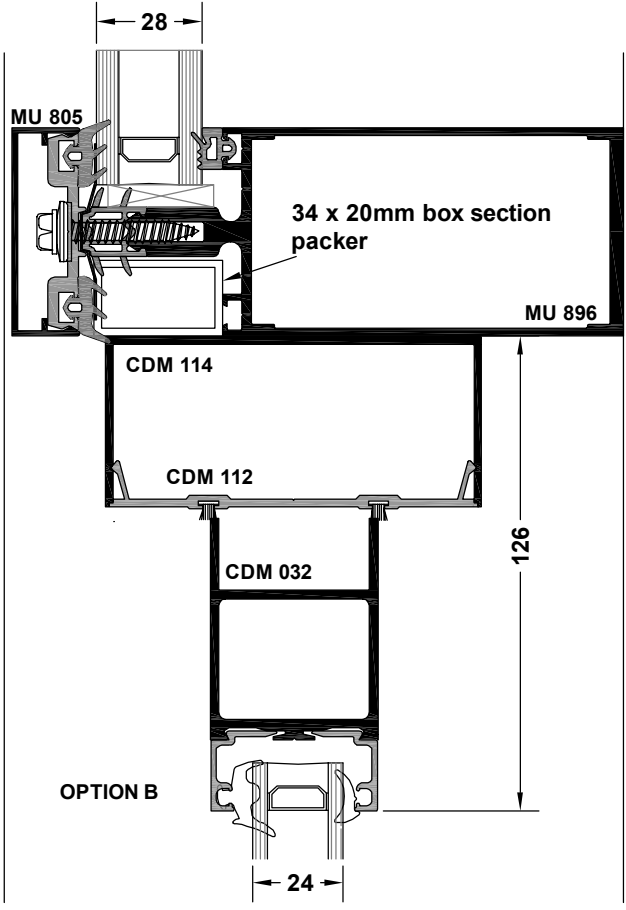
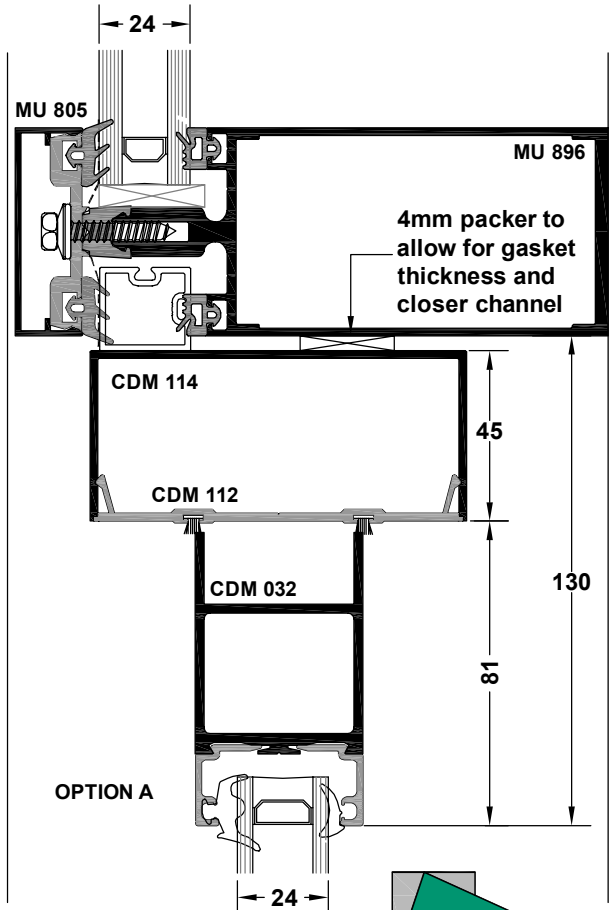
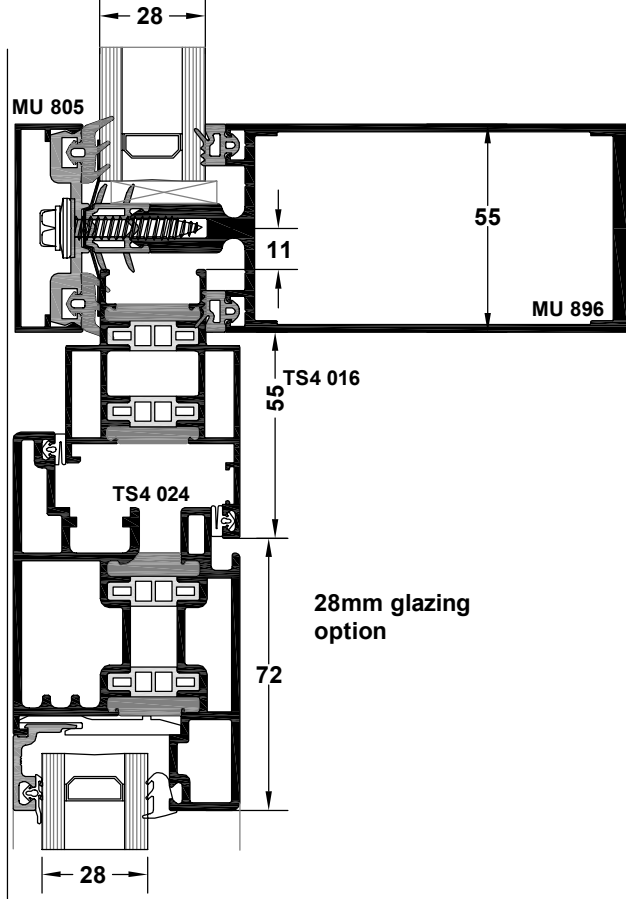
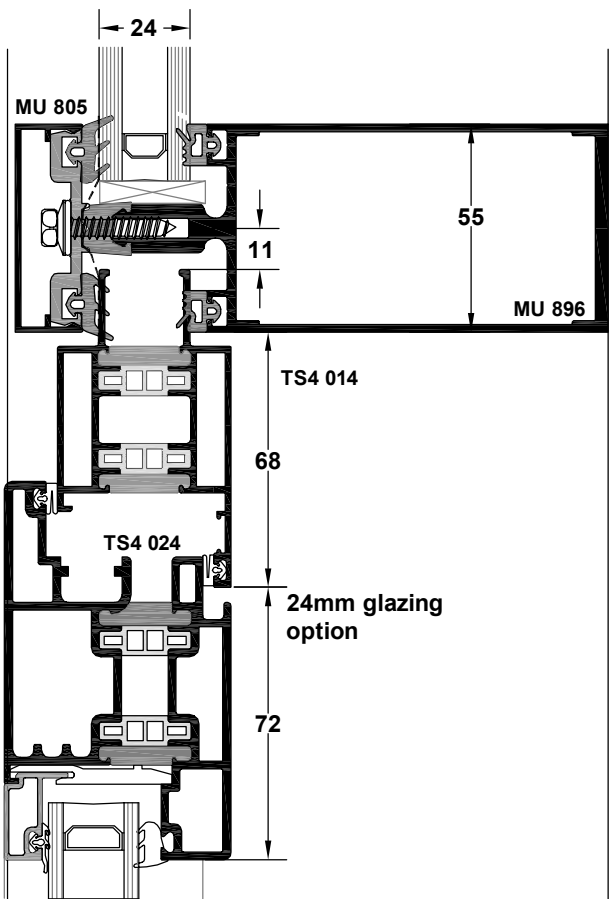

Section 1.1.20

Revision : B (-/-/-)

# MU 800 SERIES MULLION DRAINED SYSTEM

Typical jamb detail

Scale 1:2

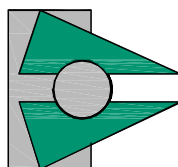
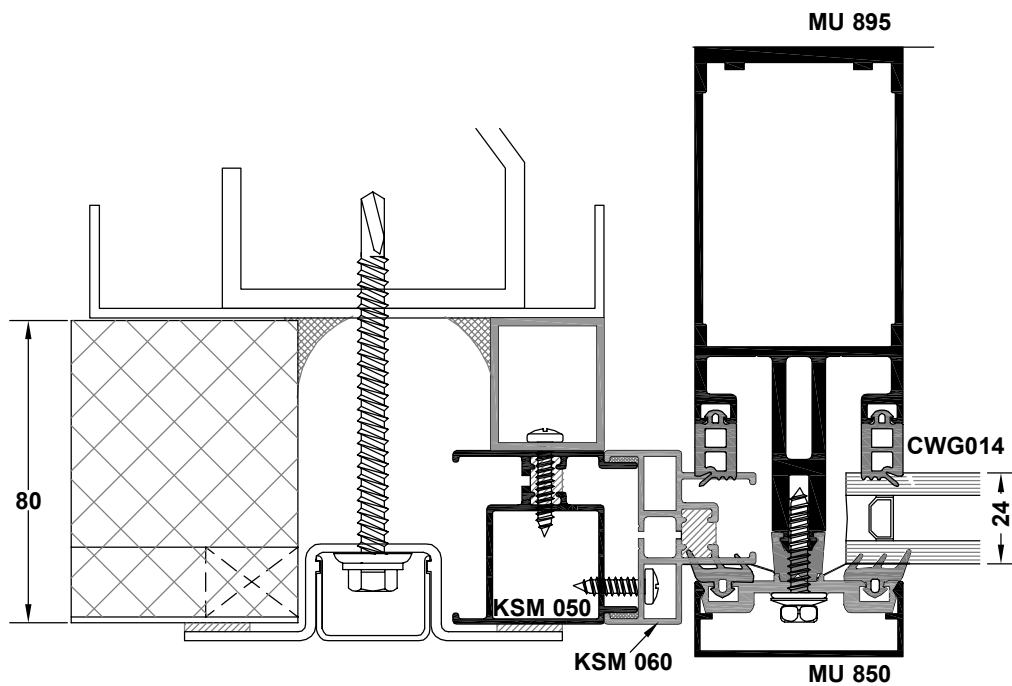
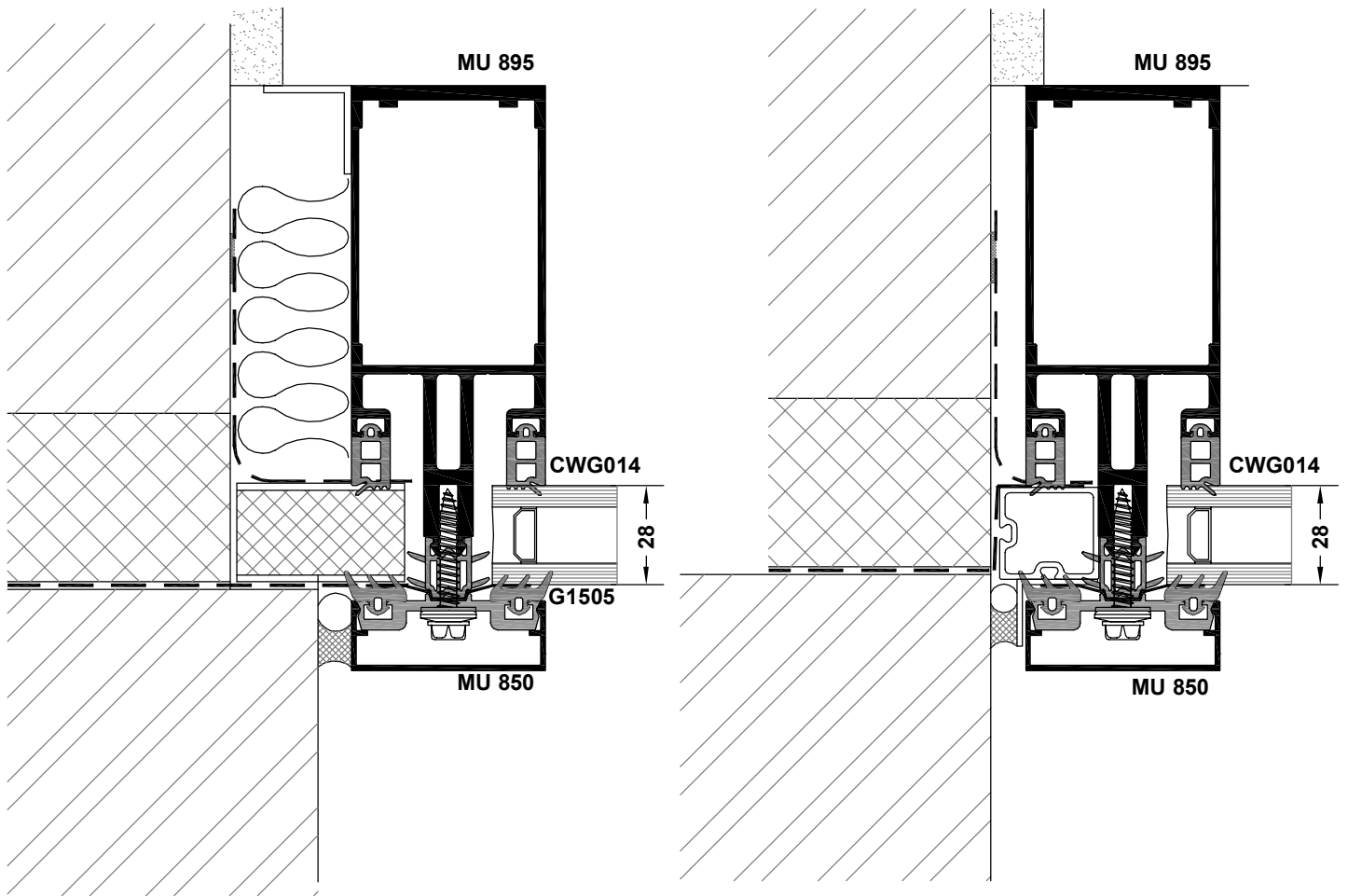

Section 1.1.21

Revision : B (---)



# MU 800 SERIES MULLION DRAINED SYSTEM

Typical door jamb detail

Scale 1:2

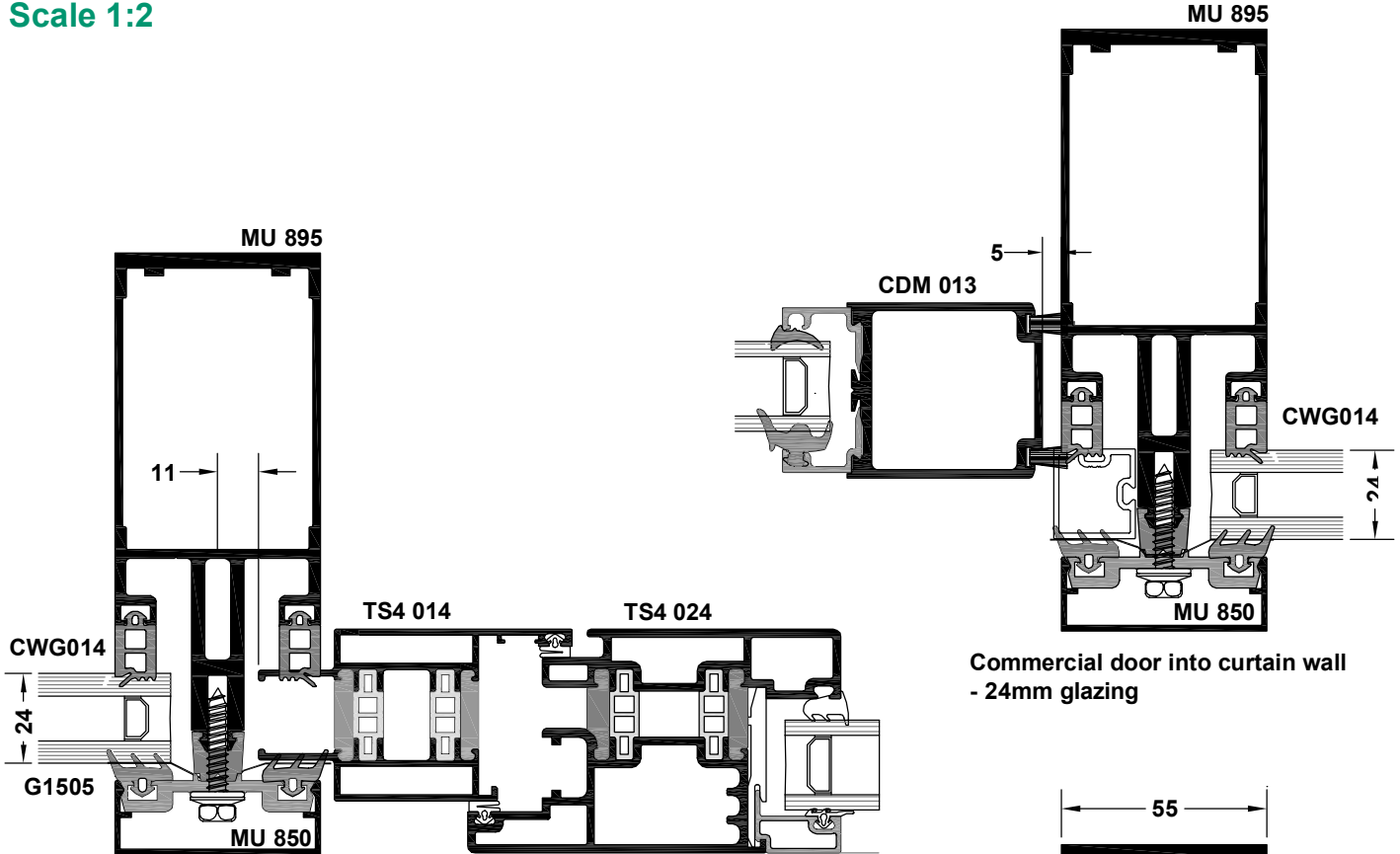

Rebated door into curtain wall - 24mm glazing

Commercial door into curtain wall - 24mm glazing

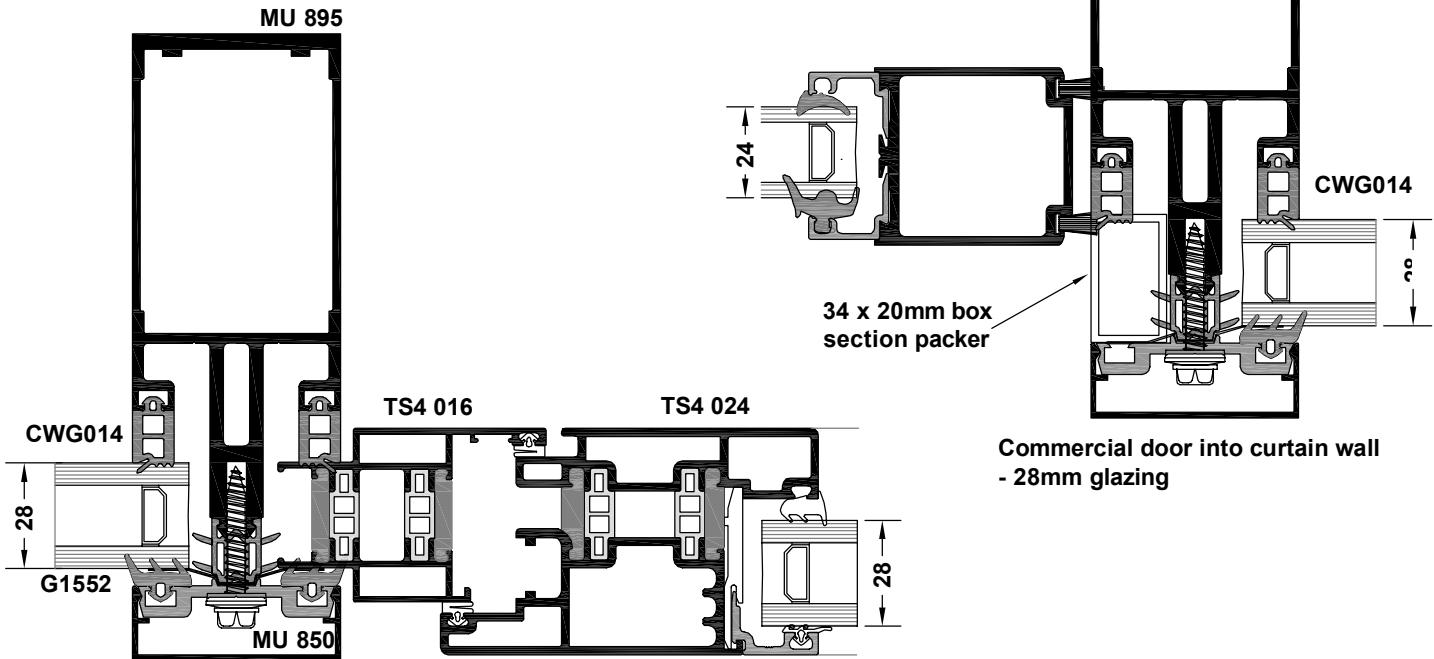

Rebated door into curtain wall - 28mm glazing

Commercial door into curtain wall - 28mm glazing

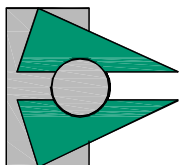

# MU 800 SERIES MULLION DRAINED SYSTEM

## Corner Assemblies

Scale NTS

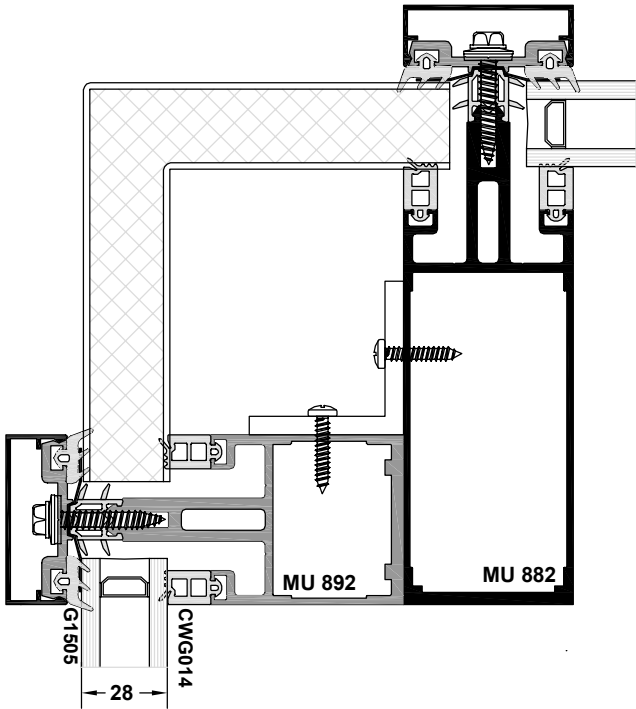

External corner with MU 882 & MU 892

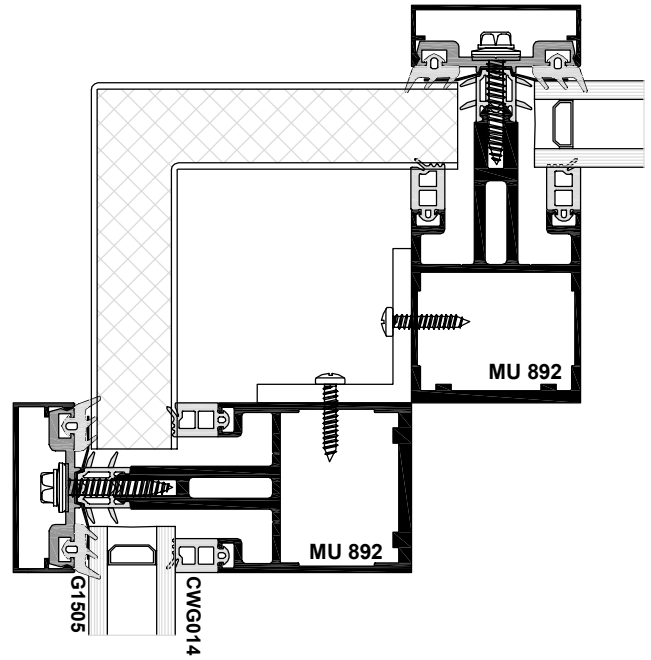

External corner with MU 892

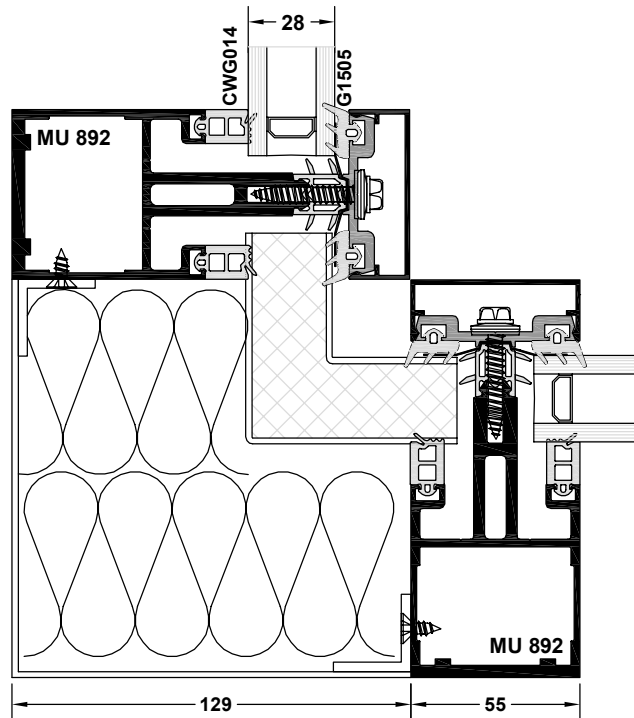

External corner with MU 892

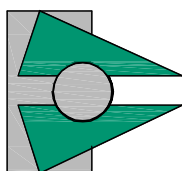

# MU 800 SERIES MULLION DRAINED SYSTEM

Typical head detail - sloped glazing

Scale 1:2

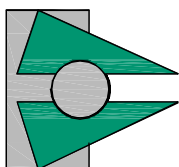
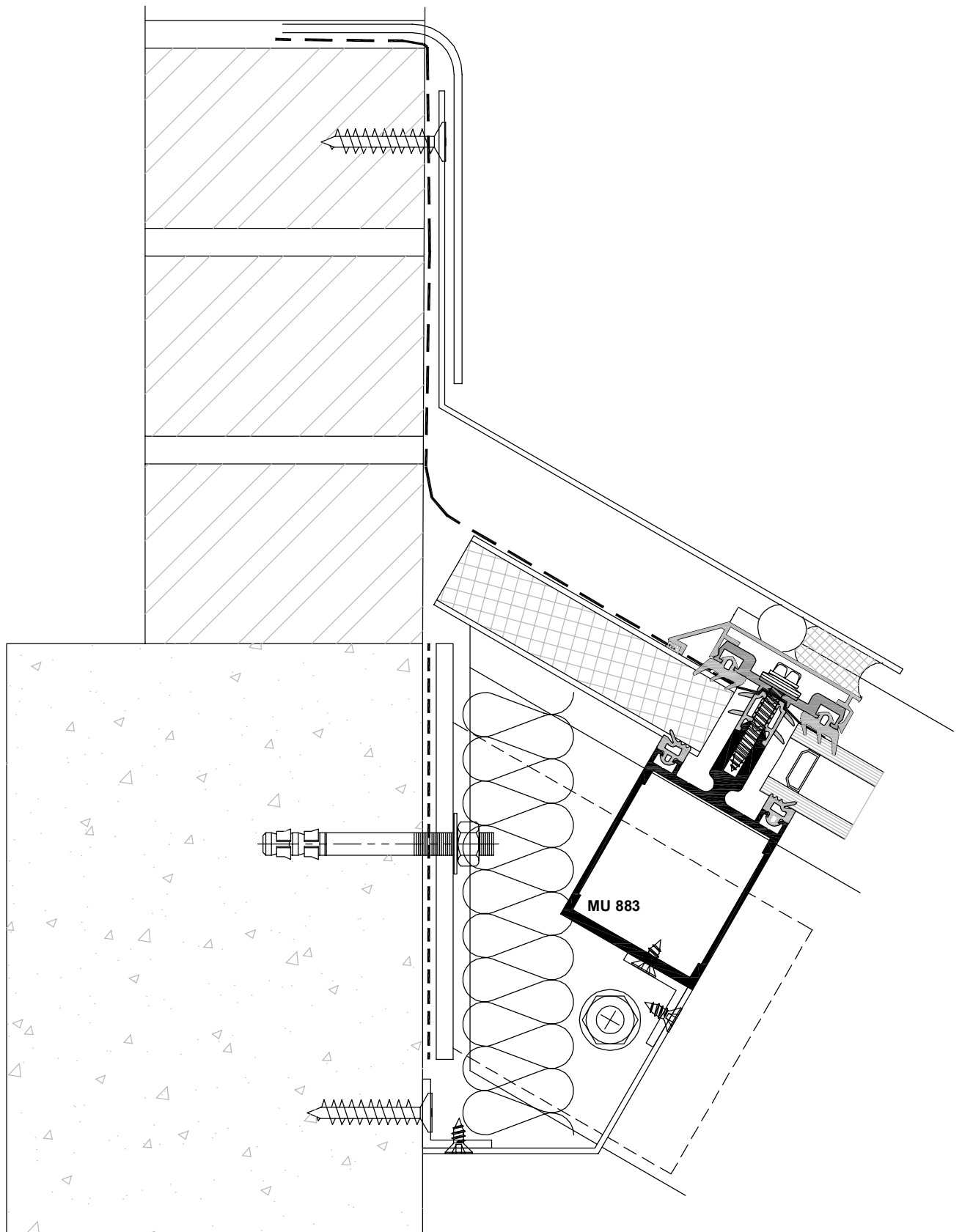

# MU 800 SERIES MULLION DRAINED SYSTEM

Typical eaves detail

Scale 1:2

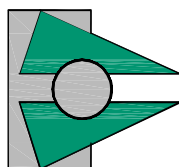
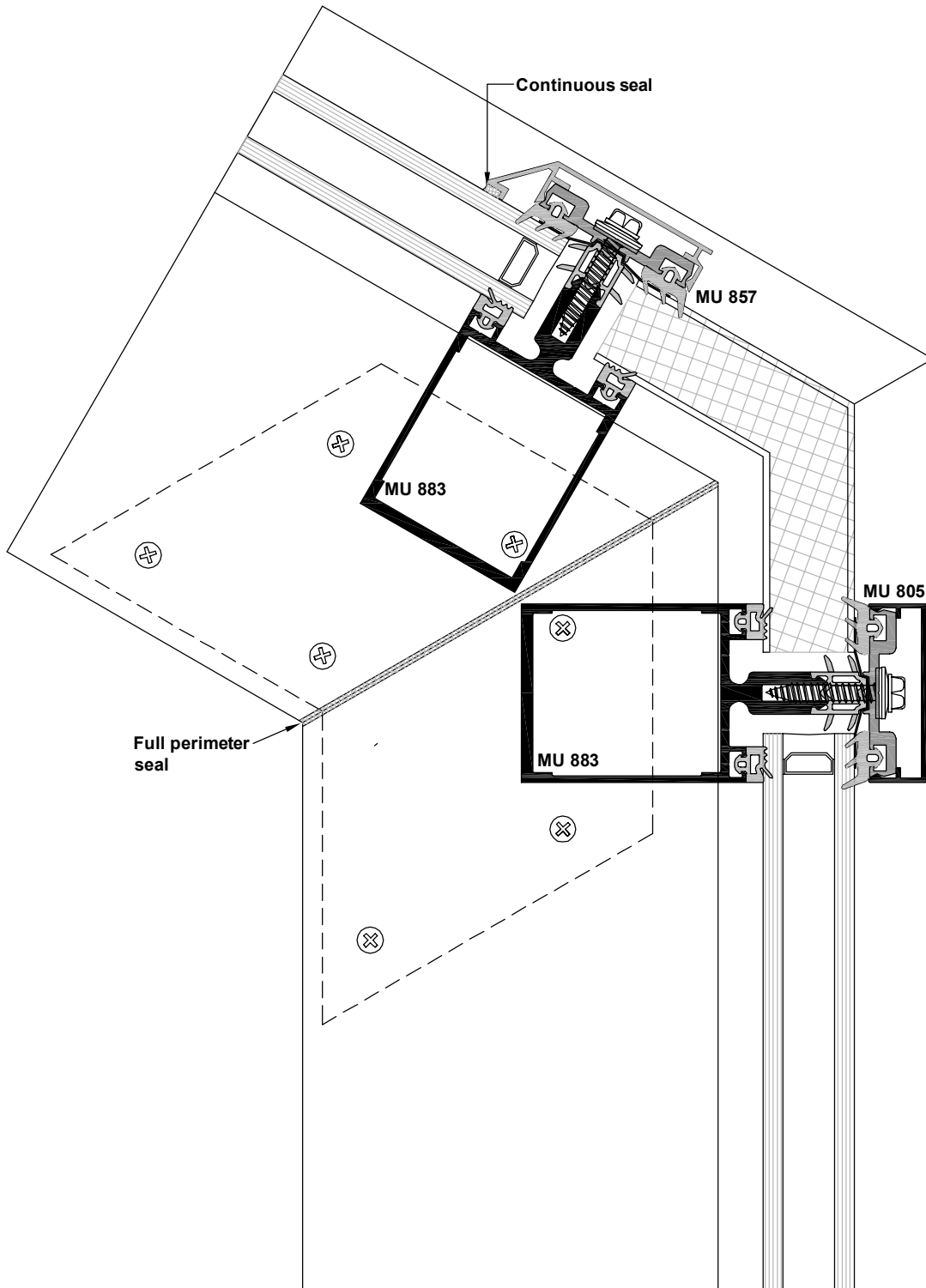

# MU 800 SERIES MULLION DRAINED SYSTEM

Typical jamb detail - Sloped glazing

Scale 1:2

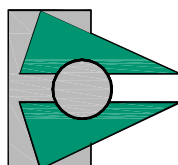
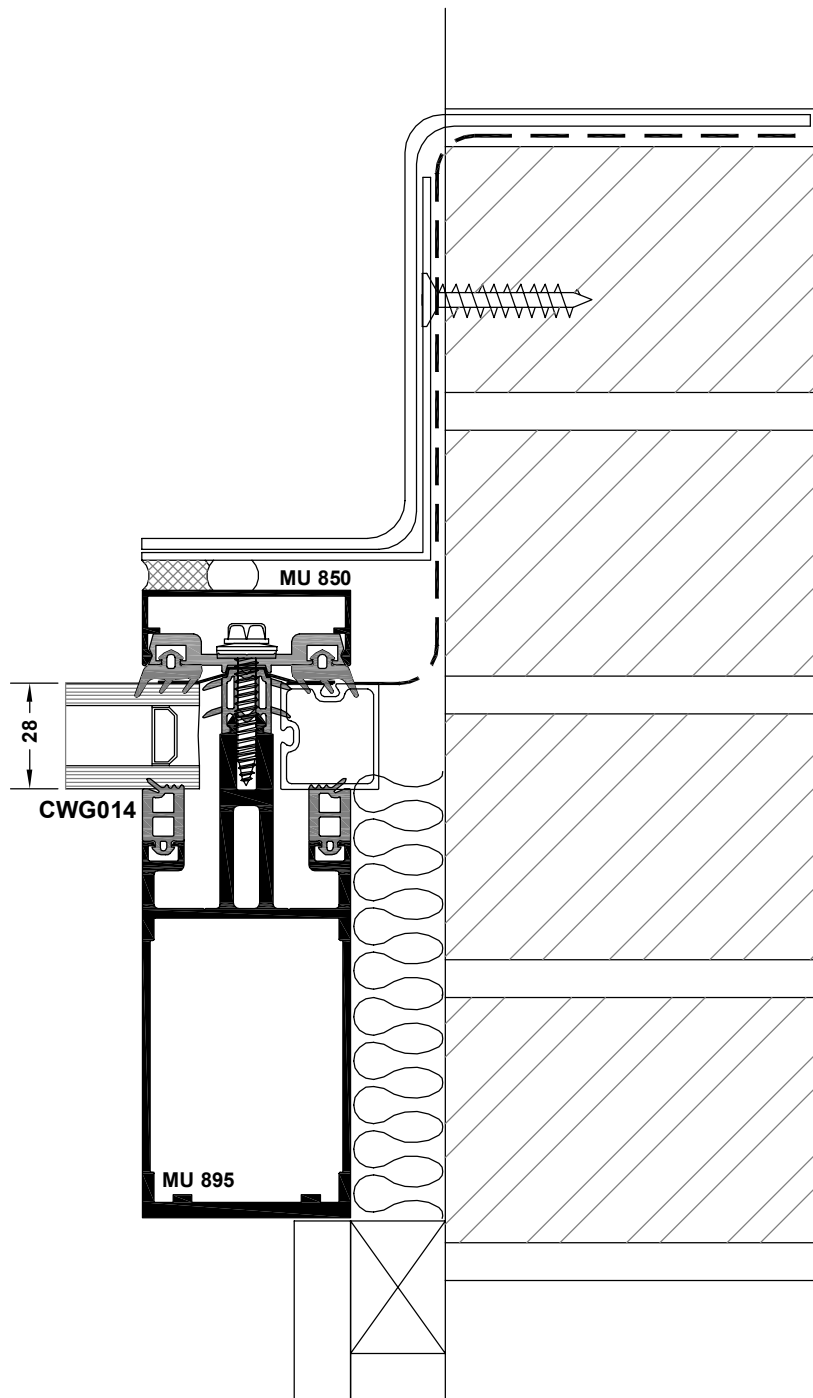

# MU 800 SERIES MULLION DRAINED SYSTEM

False mullion detail

Scale 1:2

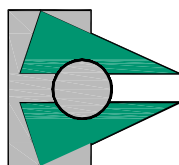
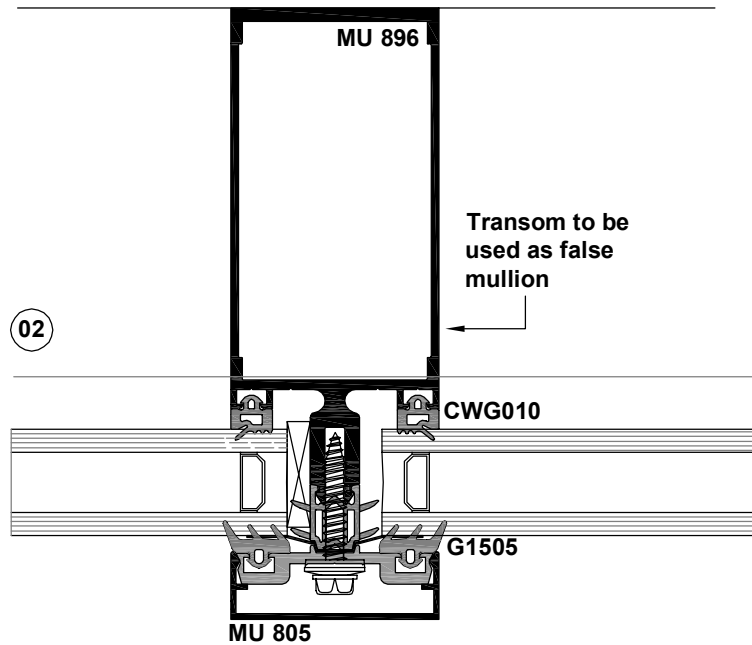
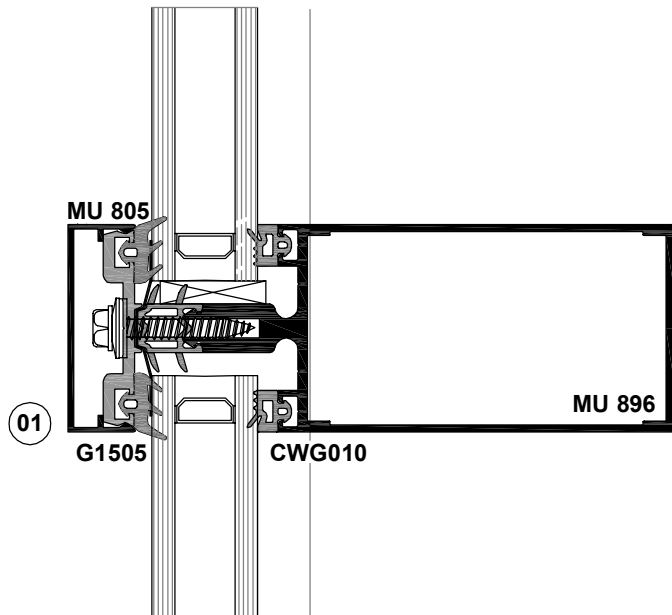
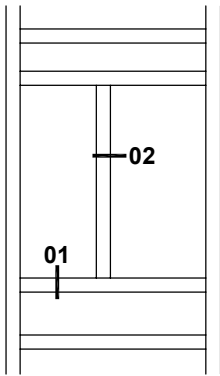

# MU 800 SERIES MULLION DRAINED SYSTEM

## Typical ridge detail

Scale NTS

Apply a perimeter seal around joint prior to fixing in position

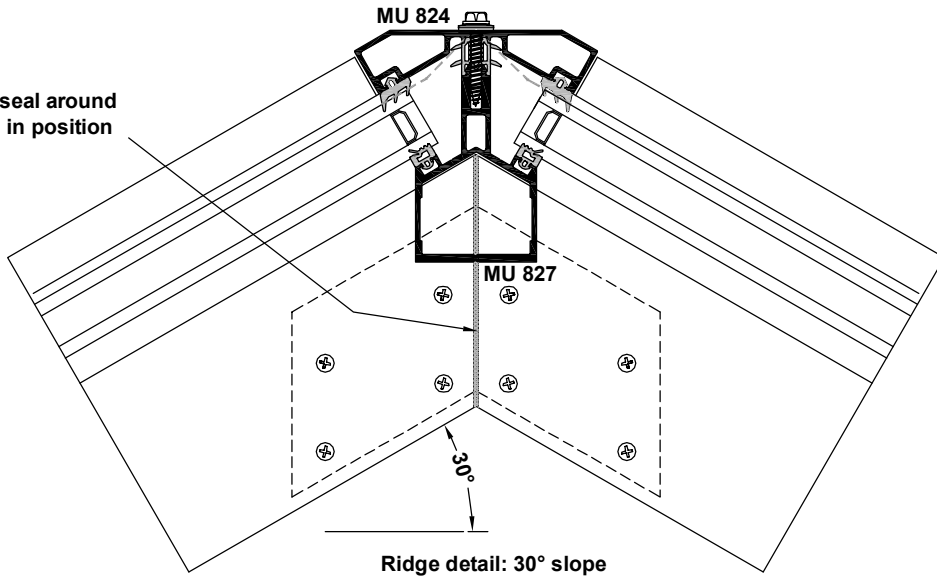

Ridge detail: 30° slope

Apply a perimeter seal around joint prior to fixing in position

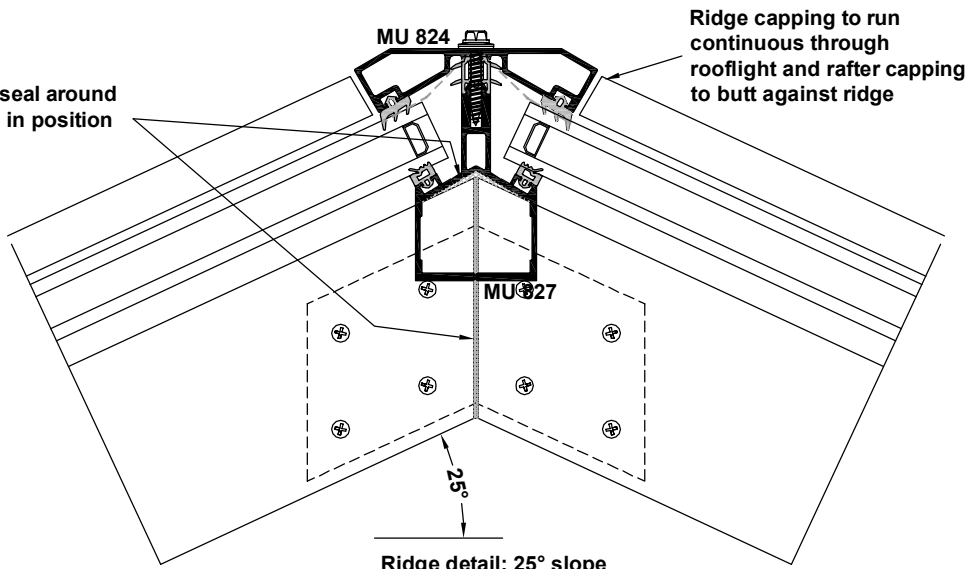

Ridge detail: 25° slope

Ridge capping to run continuous through rooflight and rafter capping to butt against ridge

Apply a perimeter seal around joint prior to fixing in position

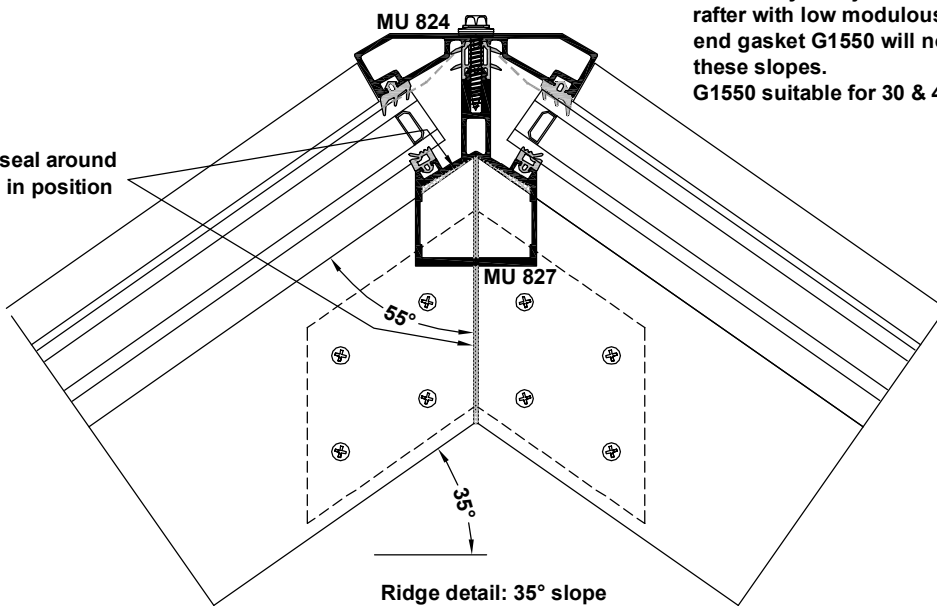

Ridge detail: 35° slope

For for roof slopes between 25 -29° and 31 to 35° fully seal joint between ridge bar and rafter with low modulus sealant. Transom end gasket G1550 will not be suitable for these slopes. G1550 suitable for 30 & 45° slopes only.

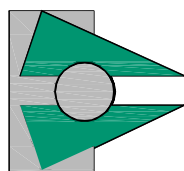

# MU 800 SERIES MULLION DRAINED SYSTEM

## Typical ridge detail

Scale NTS

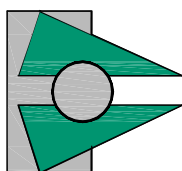
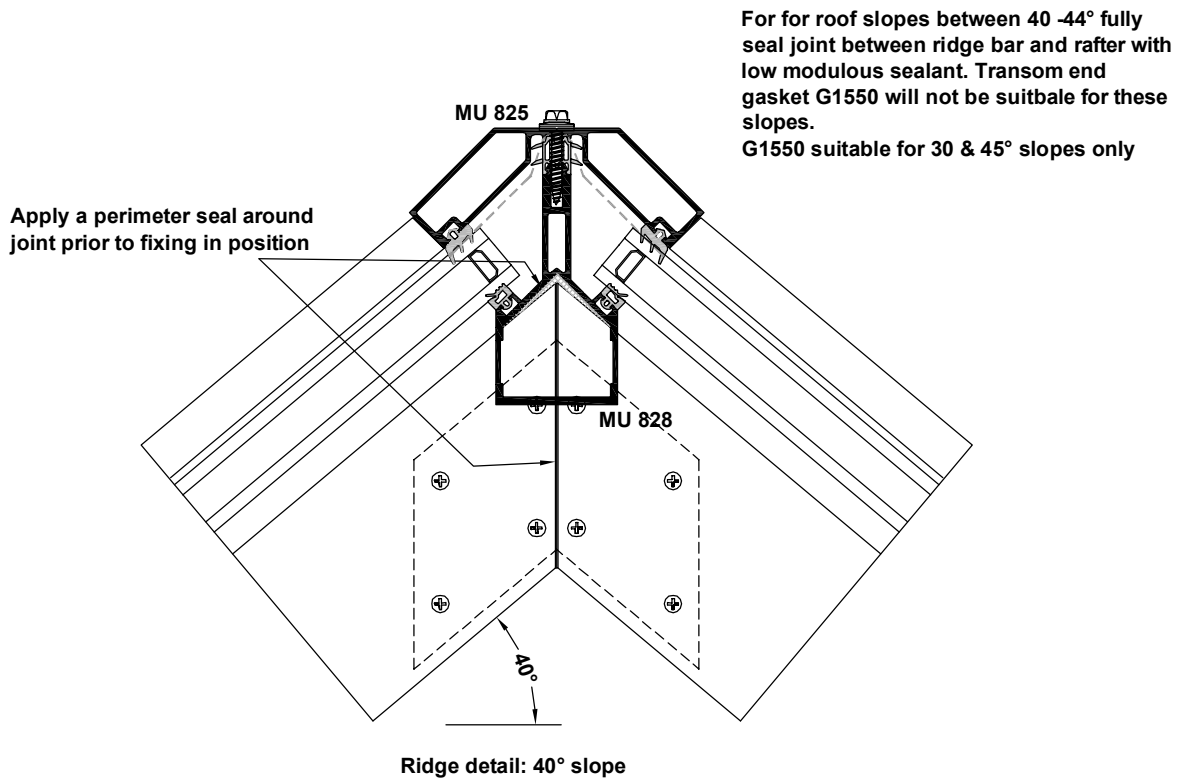
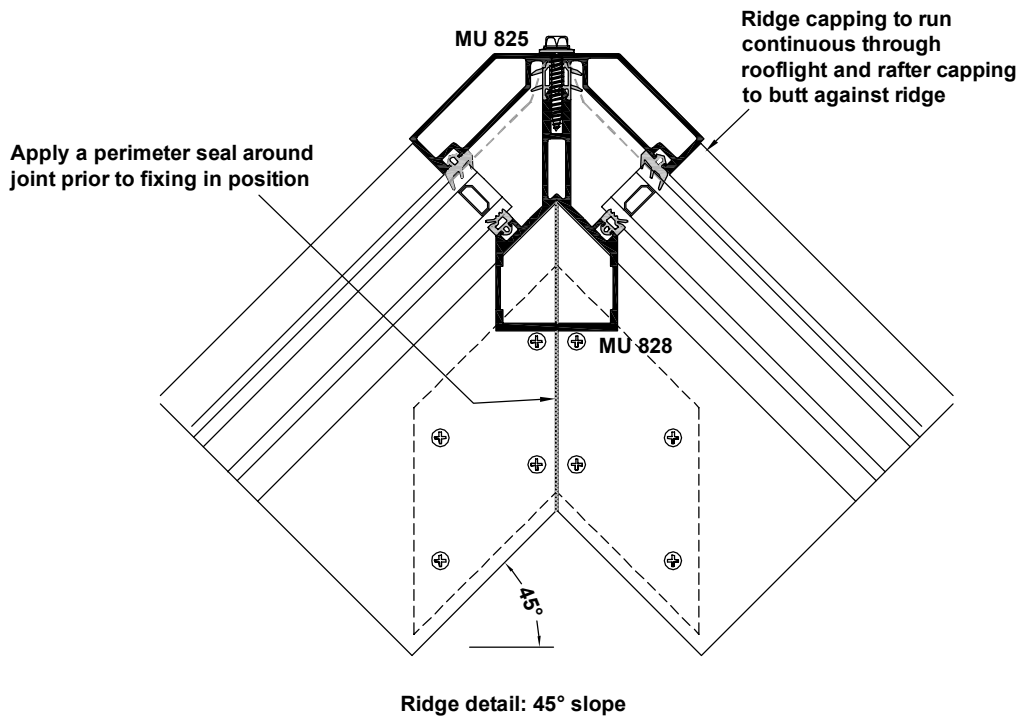



# MU 800 SERIES MULLION DRAINED SYSTEM

Double transom ridge detail

Scale 1:2

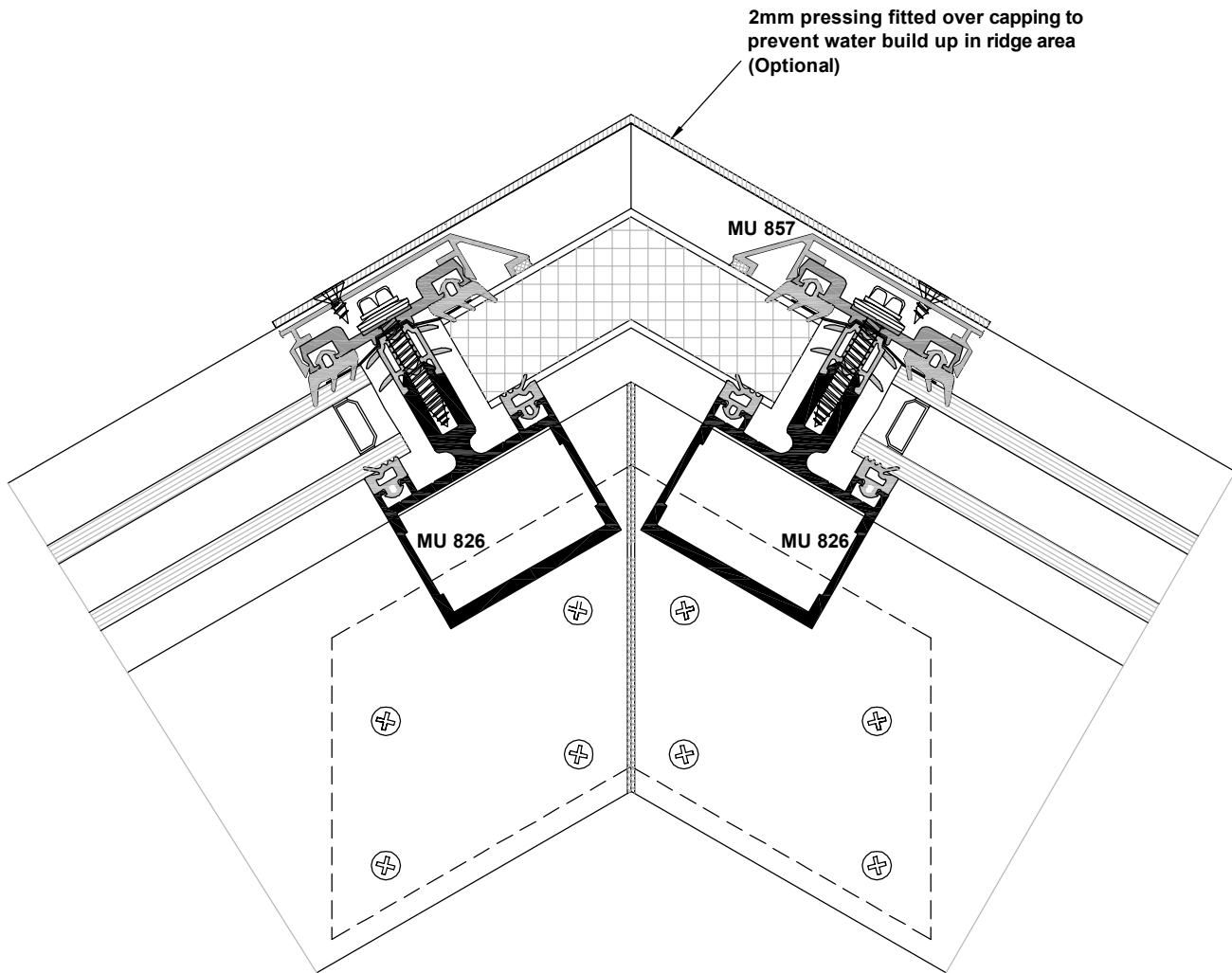

2mm pressing fitted over capping to prevent water build up in ridge area (Optional)

MU 857

MU 826

MU 826

Ridge detail:  
Suitable for all roof slopes

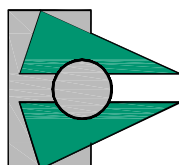

# MU 800 SERIES MULLION DRAINED SYSTEM

Typical cill detail - Sloped glazing

Scale 1:2

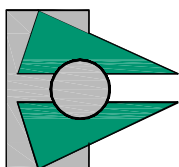
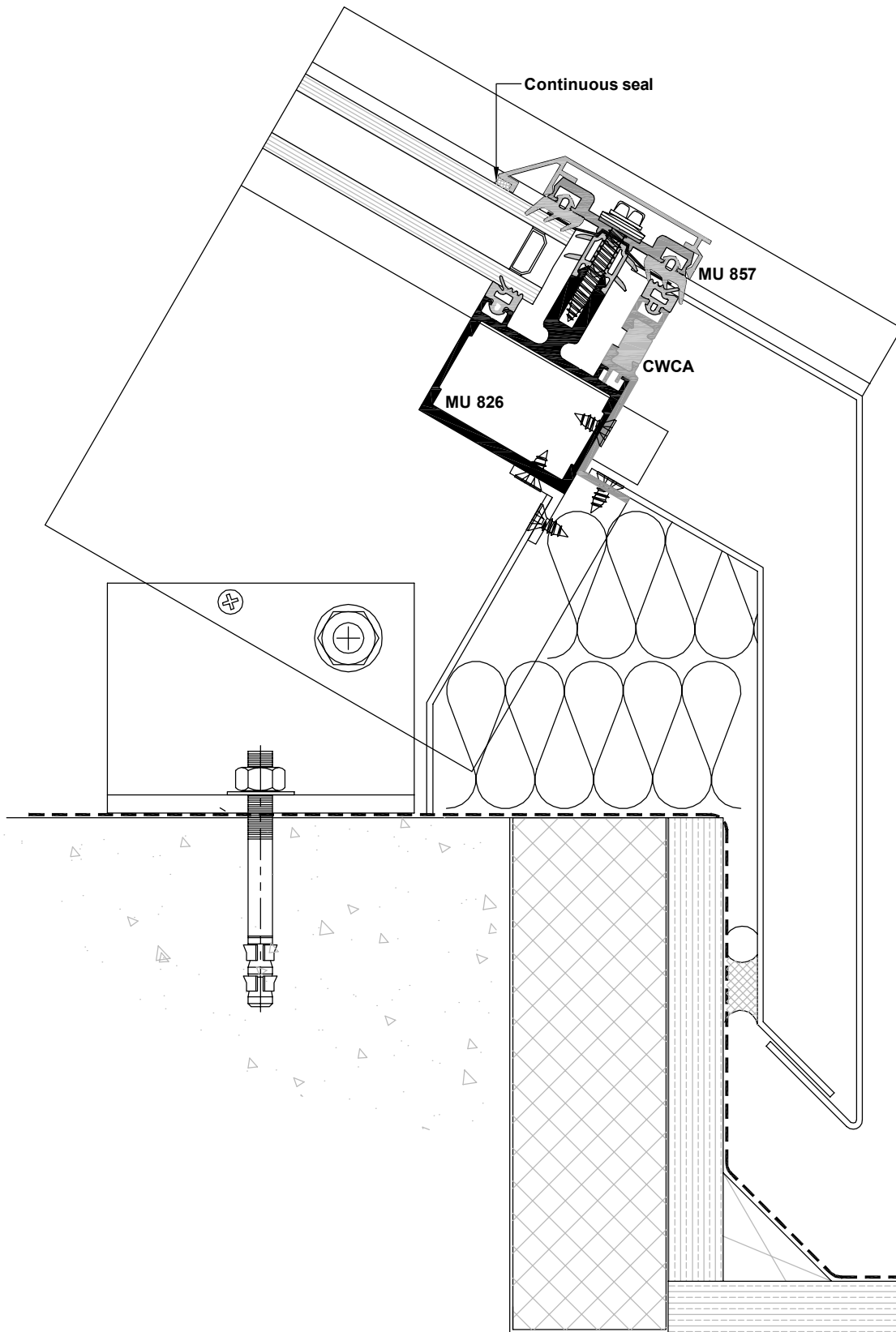

# MU 800 SERIES MULLION DRAINED SYSTEM

Typical details - MU899-60

Scale NTS

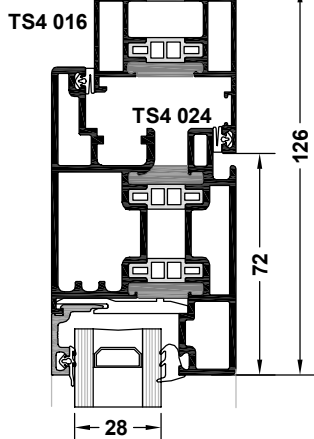
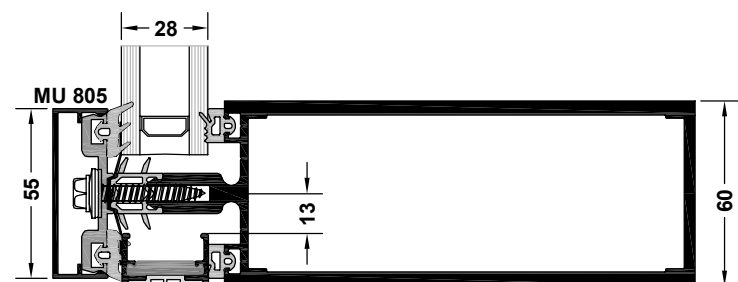

TS4 024 - Open out,  
Externally beaded door.

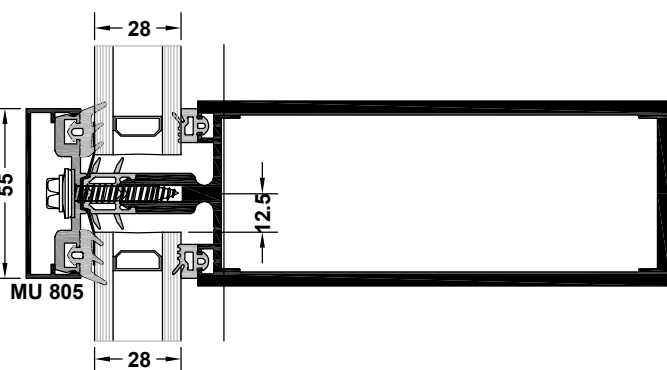

MU899-60 - transom detail

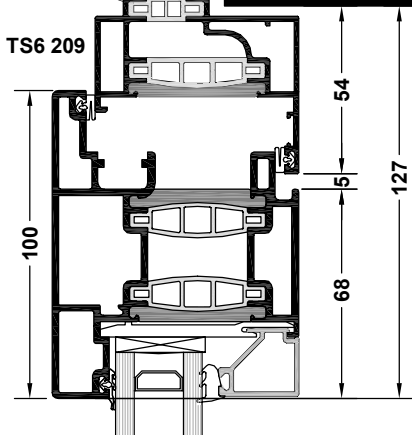
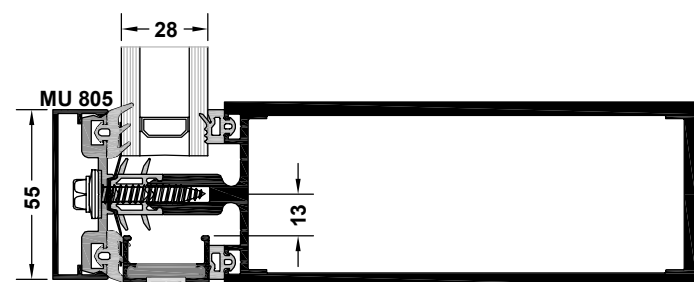

TS6 022 - Open out,  
Internally beaded door.

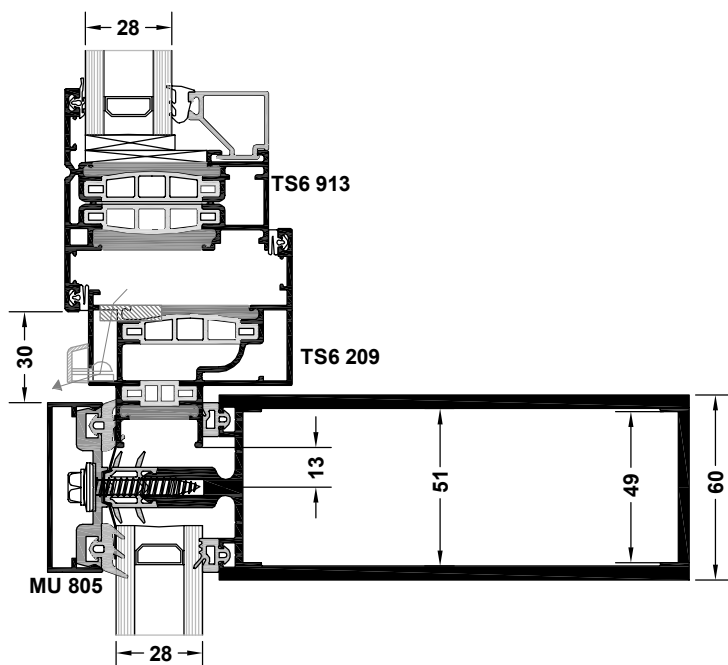

TS66 insert .

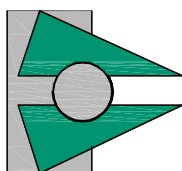

# MU 800 SERIES MULLION DRAINED SYSTEM

Typical Inserts - 28mm glazing

Scale 1:2

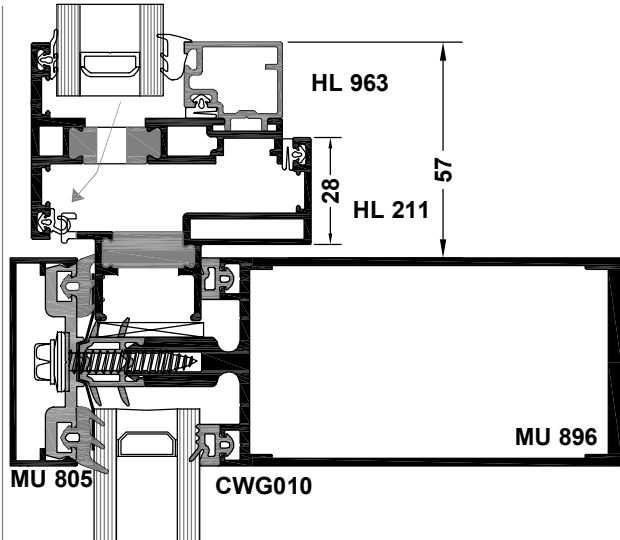

**HL963 / HL 211**  
Slim line insert

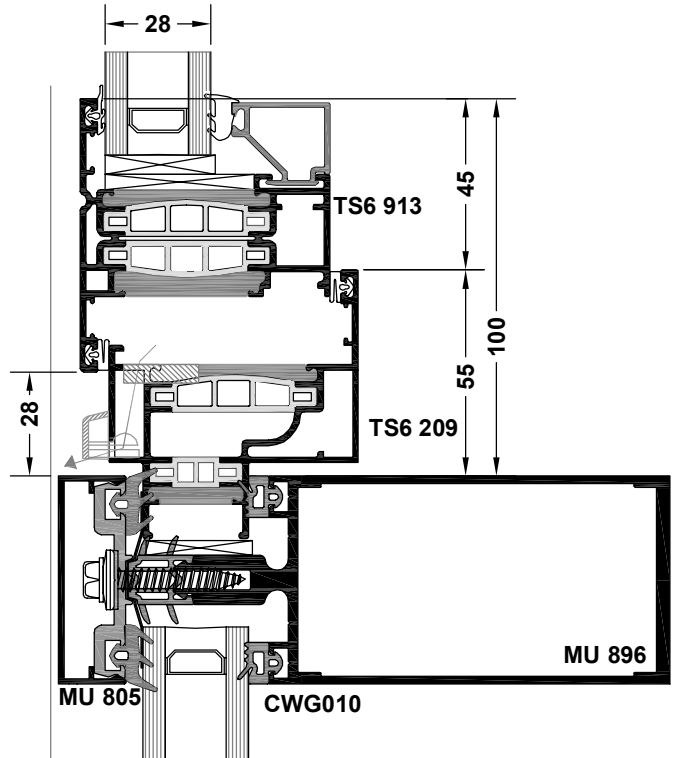

**TS6 209 / TS6 913**  
Standard insert

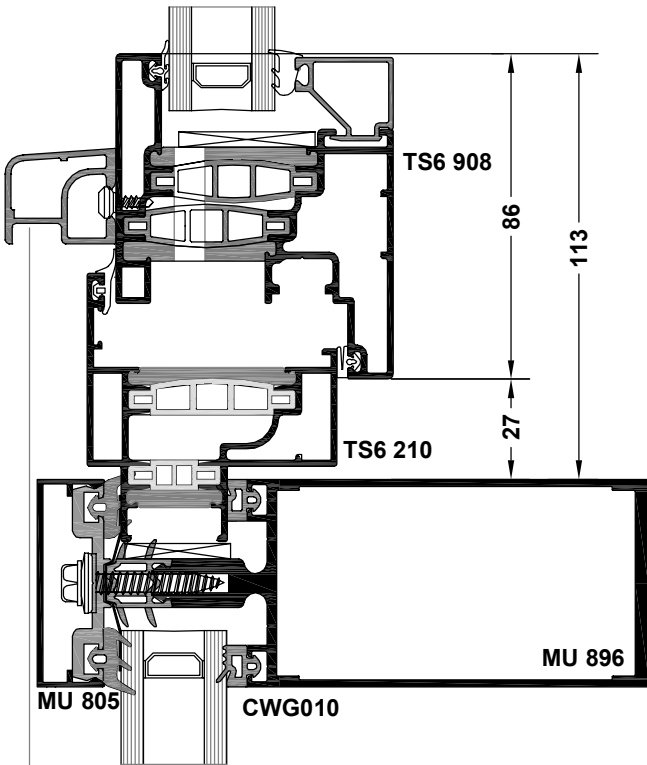

**TS6 908**  
Tilt and turn insert

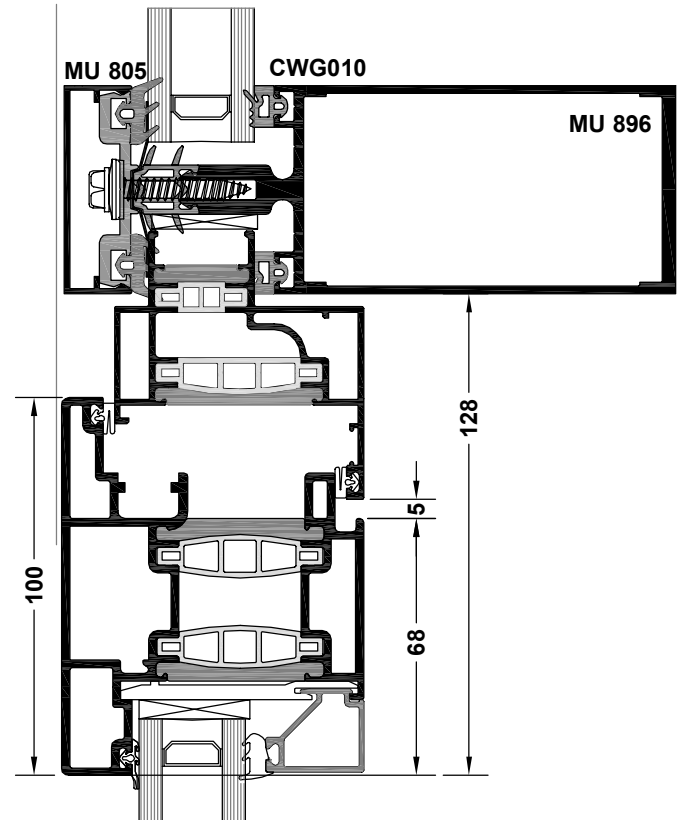

**TS6 022 - Open out,**  
Internally beaded door.

